

How To Build A Solar Panel And Solar Power System

Second Edition

By: Robert Steve Smith

Learning
Could Never
Be Easier





How To Build A Solar Panel And Solar Power System

Second Edition

By: Robert Steve Smith

Learning
Could Never
Be Easier



All contents copyright © 2009 by Robert Steve Smith.

All rights reserved worldwide. No part of this eBook may be altered nor transmitted for resale unless given permission from the author. This publication can be used for his or her own use, as long as no part of it is altered.

This eBook can be stored on a hard drive, CD, or other storage medium. You may print this e-book for your own personal at-home reading.

You are not allowed to:

- Modify it in any way. The entire e-book must remain exactly intact.
- Claim the copyright as your own.
- Distribute for sale or otherwise in any printed version whatsoever unless given permission from the author. (You may not print it out and bind it as a hard copy book for distribution.)
- Post on a website without express written permission from the author.

By acquiring this e-book and its accompanying materials, you are agreeing to comply with the terms as outlined above. The information in this eBook is copyrighted. Many hours went into creating this eBook and I would ask that you do not share this information with others that have not purchased this eBook.

Legal Notices: While all attempts have been made to provide effective, verifiable information in this eBook, the author assumes no responsibility for errors, inaccuracies, or omissions, and shall in no event be liable for any loss of profit or any other commercial damage, including but not limited to special, incidental, consequential, or other damages. This publication is designed to provide accurate and authoritative information in regard to the subject matter covered.

Trademarks: This eBook identifies product names and services known to be trademarks, registered trademarks, or service marks of their respective holders. They are used throughout this book in an editorial fashion only. In addition, terms suspected of being trademarks, registered trademarks, or service marks have been appropriately capitalized, although the author cannot attest to the

accuracy of this information. Use of a term in this book should not be regarded as affecting the validity of any trademark, registered trademark, or service mark. The author is not associated with any product or vendor mentioned in this book.

About The Author



Robert Steve Smith is the author of *How To Build A Solar Panel And Solar Power System*.

Robert, a college student at Middle Tennessee State University majoring in Engineering Technology, with a concentration in Computer Engineering Technology and a minor in Computer Science, has dedicated a decent amount of time learning how solar panels work, and how solar panels are built. Robert became involved in online solar related communities where he learned many of the basic fundamentals about what was needed to create a solar power system. Robert has experienced firsthand what it is like to build a solar panel and has provided support to individuals new to the solar industry. Robert has also created a series of free online videos that teach you how to build a complete 63 watt solar power system and other useful solar energy information. For more information visit Robert's website at: SolarTechTown.com.

Dedication

This eBook is dedicated to anyone who finds it useful.

Acknowledgments

I would like to express my appreciation to all online solar communities. Without the generous support received by numerous individuals, my success of building a full solar power system would not be possible. Additionally, I would most likely not be writing this eBook if it was not for the elongated list of experienced community members. A large portion of the content within this eBook has come from my own experiences and from many of the common questions asked by those new to solar energy.

Table of Contents

[About The Author](#)

[Introduction](#)

[Materials Needed To Build Solar Panel](#)

[Materials Needed To Build Solar Power System](#)

[Recommended Stores To Buy Materials](#)

Step 1 - [Building The Frame](#)

- [Time To Paint](#)

Step 2 - [Assembling the Solar Cells](#)

- [Soldering Solar Cells Together](#)

Step 3 - [Placing the Solar Cells in the Frame](#)

Step 4 - [Applying Slygard 184](#)

Step 5 - [Installing the Plexiglass on the Frame](#)

Step 6 - [Installing the Junction Box](#)

Step 7 - [Learning About Solar Power System Components](#)

- [Charge Controller](#)
- [Deep Cycle Battery](#)
 - [Charging a 12 volt Deep Cycle Battery](#)
- [Inverter](#)

Step 8 - [Hooking Up The Solar Power System](#)

Step 9 - [Mounting The Solar Panel On To A Roof](#)

[Conclusion](#)

Introduction

As you may or may not know, over history many types of energy sources have been discovered such as, nuclear power, fossil fuels, and renewable energy. Between the three, renewable energy has grabbed more and more attention over the last few years. Many businesses and individuals are now looking for ways to leave a lesser carbon footprint and alternatives for using fossil fuels.

Two well known devices for creating renewable energy are solar panels and wind turbines.

For those of you who may not know, a **solar panel** is an electrical device that is filled with an array of solar cells. The solar cells collect energy from the sun or light and convert that energy received into electricity, or direct current (DC). Most devices in your home like a lamp, TV, or oven use alternating current (AC). So to convert that DC from the solar panel into AC so that you can power items in your home, an inverter is used. We will get more into this at a later point in this eBook.

A **wind turbine** obviously collects its energy from the wind. The energy a wind turbine receives from the wind is converted into electricity, or DC, similar to a solar panel.

Between the two, most people find solar panels more convenient, or are forced to use solar panels because of their location. To produce the best results from a wind turbine, one would need to reside where there is a large amount of wind. As for a solar panel, at this point you should know that one would produce the best results residing where lots of sunlight is received. I fell into the category of receiving more sunlight than wind. So I soon decided to build a solar panel. I will teach you how to build one yourself later on in this eBook.

Solar panels have been around longer than what most people think, but we are now finally investing more time into making solar panels one of the standard

energy sources. One reason is, we receive energy from the sun every day. About 965 trillion kWh of energy is produced by the sun every day. Why not take advantage of that free energy? For many business owners and average consumers, professional made solar panels are still fairly expensive to invest in. Many people find it cheaper to manufacture the solar panels themselves rather than purchasing a professional solar panel. However, this will not be case for everyone. There are many hidden details that come with making a reliable solar panel that some individuals or DIYERs (Do It Yourselfers) simply are not aware of and find out the hard way. There are many methods for creating a solar panel, but not all methods provide the same reliability that a professional solar panel does.

The method used in this eBook will give you a basic understanding of how to build a solar panel. Once you have a basic understanding of how a solar panel is built, you can start to modify the panel by adding or using different materials specific to your needs. If you are completely new to solar panels like I was when I first started, this eBook will open the doors to new knowledge that you can use to expand on. As mentioned earlier, there are many ways to build a solar panel from a DIY perspective. However, not all methods provide the same reliability that a professional manufactured solar panel does. This eBook is targeted toward those who do not have access to professional machines that large solar manufactures have available. Most tools and materials found in this eBook can be purchased at most local or online retail stores.

With that said, do not expect from this eBook to build a solar panel that will match the quality of a professionally made solar panel. Instead, expect to gain more knowledge and experience about one of many ways to build a solar panel.

At this point you should have a general idea about what a solar panel is, and how a solar panel works. By now I am sure you are extremely eager to jump in and learn how to build a solar panel. Next I will point out the general materials you will need, and afterwards explain the full process for building a solar panel and a solar power system.

Materials Needed To Build Solar Panel

* HIS = Home Improvement Store

| Item | Store |
|---|--------------------------------|
| 36 Solar Cells (Recommend Evergreen Solar Cells) | eBay |
| 60 ft. of Tabbing Wire | eBay |
| 15 ft. of Bus Wire | eBay |
| Rosin Flux Pen | eBay |
| Soldering Iron | HIS |
| Tube/Roll of Solder | eBay |
| Decent Soldering Iron | HIS |
| 2x4 Pressure Treated Plywood | HIS |
| 2x4 Sheet of Plexiglass | HIS |
| 2x4 Sheet of Pegboard | HIS |
| 1x2x10 Pressure Treated Plywood | HIS |
| Sander and Sand Paper | HIS |
| Staple Gun or Stapler | HIS |
| UV Protector Sealant (white) | HIS |
| Paint Brush or Roller | HIS |
| Transparent Silicone | HIS |
| Caulk Gun | HIS |
| Digital Multimeter | eBay Radio Shack Walmart |
| Crimping Pliers | HIS |
| Tile Spacers | HIS |

| | |
|--|------|
| Mending Plates | HIS |
| Power Drill | HIS |
| Drill Bit | HIS |
| Power Drill | HIS |
| Milder Saw (Hand Saw) | HIS |
| 4 Hole Straight Brackets (Amount May Vary) | HIS |
| Solar Panel Junction Box | eBay |
| Roofing Cement | HIS |
| 3x 5/4" x 6" x 3 1/2 ft. Pressure Treated Plywood | HIS |
| 2x 4" x 4" x 4 ft. Pressure Treated Plywood | HIS |
| 14x L-Brackets | HIS |
| Ladder | HIS |
| Tape Measure | HIS |
| Hammer | HIS |
| 3" Screws (Made For Pressure Treated Plywood) | HIS |
| 4" Screws (Made For Pressure Treated Plywood) | HIS |
| 2 1/2" Screws (Made For Pressure Treated Plywood) | HIS |
| Slygard 184 | eBay |

Materials Needed to Build Solar Power System

| Item | Where To Purchase |
|--|-------------------|
| Charge Controller | eBay.com |
| | NorthernTool |
| 12 volt Deep Cycle Battery | AutoZone |
| | Walmart |
| Kill A Watt Meter (Optional) | eBay.com |
| | eBay.com |
| Inverter | Walmart |
| | AutoZone |
| American Wire Gauge (size may vary) | HIS |

Recommended Stores to Buy Materials:

At the following stores you should be able to find everything listed on the list above:

- Home Depot
- Lowes
- Radio Shack
- Walmart
- eBay.com

If you are new with working with wood, power tools, and other items in the list above, I recommend the following:

- Print out the lists above and take them along with you to the store you plan to be purchasing the items from. Find someone who works at the store and ask for assistance finding the items within the list. For items you have not worked with, feel free to ask an employee at Home Depot or Lowes for example, for guidance. You can also usually find videos as well online showing examples of how to use different devices.

Step 1

Building the Frame

*Tip: Before you start building anything, I recommend buying all the materials beforehand. This will prevent you from having to run back and forth to the store, wasting time and money. For this instructional, I am going to assume you are using 3x6 Evergreen solar cells, but you can still use this guide for most typical multi-cryatalline silicon solar cells.

1. What you first need to start off with is building the frame. The items needed to build the frame are as follows:

- 2x4 Pressure Treated Plywood
- 1x2x10 Pressure Treated Plywood
- UV Protector Sealant (white)
- Box of 2 in. Screws (Made For Pressure Treated Wood)
- Milder Hand Saw (or regular hand saw)
- Power Drill and Drill Bit
- 2x4 Sheet of Pegboard
- Sander and Sand Paper
- Paint Brush or Roller

Tell someone at
Lowe's / Home Depot to cut the
1x2x10 Plywood
to fit around the perimeter of a
2x4 piece of plywood.

*Tip: A pair of horses will help as well for holding up your frame while you assemble it. You can usually purchase these from most home improvement stores.

2 So next you want to start with your base piece (2x4 Pressure Treated

Plywood) which is going to hold everything together. Go ahead and place the base piece on top of your horses or platform that you will be assembling on. Next, have Lowes / Home Depot cut up the 1x2x10 piece of pressure treated plywood to the right dimensions to fit around the edge of the plywood. Refer to the images below:

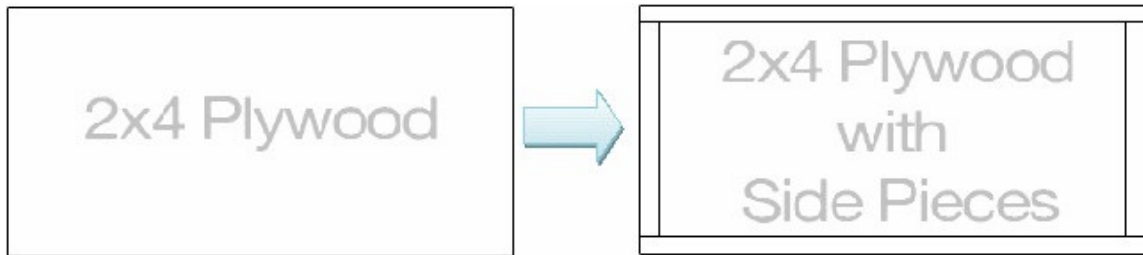

Once you have placed the perimeter pieces of plywood around the base as you see in the picture above, go ahead and mark where you will drill your holes. I recommend having your screws about 4 inches apart. It really does not have to be perfect, but as long as your screws are not too far apart (such as 8 inches apart) to where your wood has large gaps where water can easily enter your frame, you should be alright. Refer to the picture below:

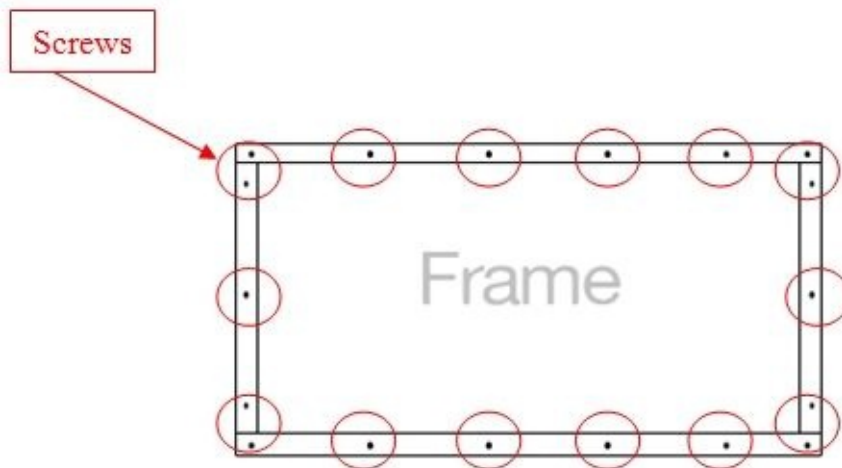

3. Optional Step: Once you finish inserting your screws, you can use a sander or sand paper to smooth out any rough edges or surfaces. This will also help to prepare your frame for painting.

4. The next step involves drilling two holes which will allow your wires to run out the back of the frame. The two holes do not need to be too wide, but wide enough so that the bus wires you'll be using can easily run through them. Refer to the pictures below:

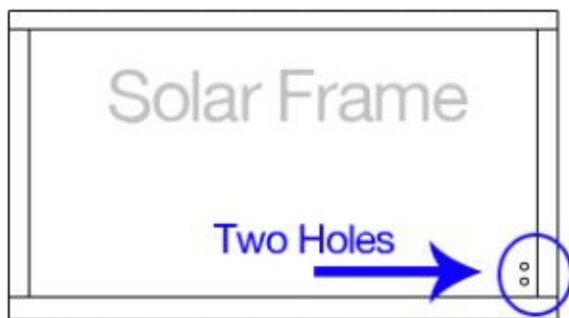

Once you have drilled both of your holes at the far end of the frame, you need to cut your pegboard to the right size. The pegboard that you purchase may be larger than what you need, so use a milder saw (a regular hand saw will do) to cut the pegboard.

Note: Be sure not to cover your pre-drilled holes (that will run the bus wires outside of the frame) with the pegboard. Refer to the picture below:

Do not at this point screw your pegboard down. You still need to paint both sides of the pegboard.

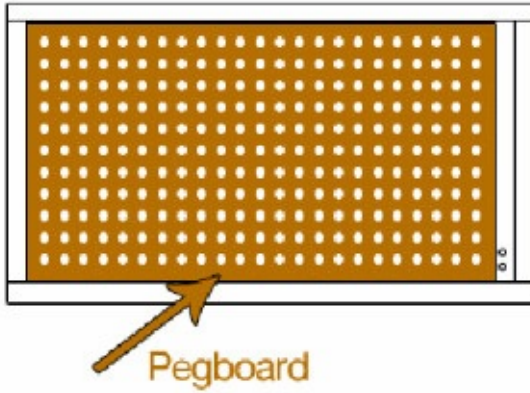

After you have cut down the pegboard to the right size (as seen in the picture above) to where it can slide in and out of the frame fairly easy, take the pegboard out of the frame and set it to the side.

Time To Paint

Just a reminder: At this point, the pegboard should not be inside the frame. You will be painting the pegboard separately and the frame separately.

5. Before you begin painting, be sure that you have mixed your UV Protector Sealant. Most people use a **paint mixer bit** that you can connect to your power drill to stir your paint up before painting. If you have no idea what this is, or how to use it, I recommend visiting Lowes or Home Depot and asking an employee in the paint department.

6. After you have your paint (UV Protector Sealant) ready to go, you can take your paint brush or roller, whichever one you prefer, and start painting the frame. Be sure to apply the solution (paint) inside **all** cracks.

Once you have completely put **1** coat of paint on one side of the frame, allow that coat to dry and go ahead and start putting **1** coat of paint on one side of the pegboard.

*Tip: Read the instructions for the paint you are using to see the recommended dry time. Most recommend 24 hours before allowing sun or water come into contact with the paint.

7. After the 1st coat has completely dried on the frame and the pegboard, flip over both the pegboard and frame, and begin to **apply 1 coat to the opposite side.**

*Follow the same procedures in **Step 1.6** for the opposite side.*

8. Once the coat of paint on the opposite side has completely dried on the frame and pegboard, flip both over and begin to put a 2nd coat of paint on both the frame and pegboard. *Repeat **Step 1.6** and **Step 1.7** for the 2nd coat.*

9. After the 2nd coat of paint has dried on both the frame and pegboard, place the pegboard inside the frame again. Begin to take some 1 inch screws (made for pressure treated plywood) and drill down the pegboard to the frame.

*Tip: Refer to the image below regarding the recommended areas to place your screws and how many:

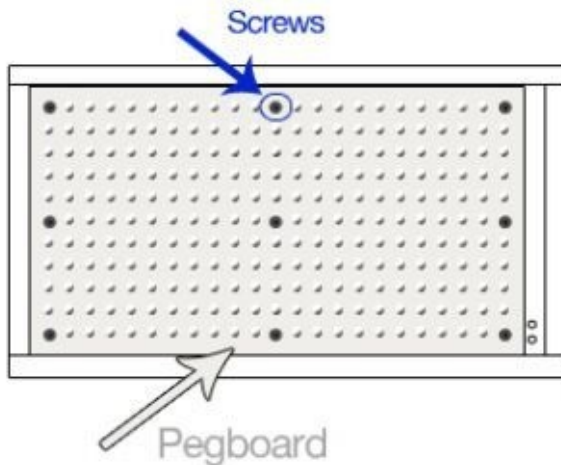

10. After screwing down the pegboard to the frame, set the entire frame to the side for now. We will come back to this later after you finish assembling the solar cells.

Step 2

Assembling the Solar Cells

Before you actually begin handling the solar cells, you need to create a template for your solar cells which will help keep the solar cells even.

1. The items you will need for this step are as follows:

- Solar Cells
- Tabbing Wire
- Bus Wire
- Rosin
- Flux Pen
- Staple Gun or Stapler
- Soldering Iron
- Solder
- Tile Spacers
- Hand Saw or Power Saw
- Spare Piece of Plywood or Card Board

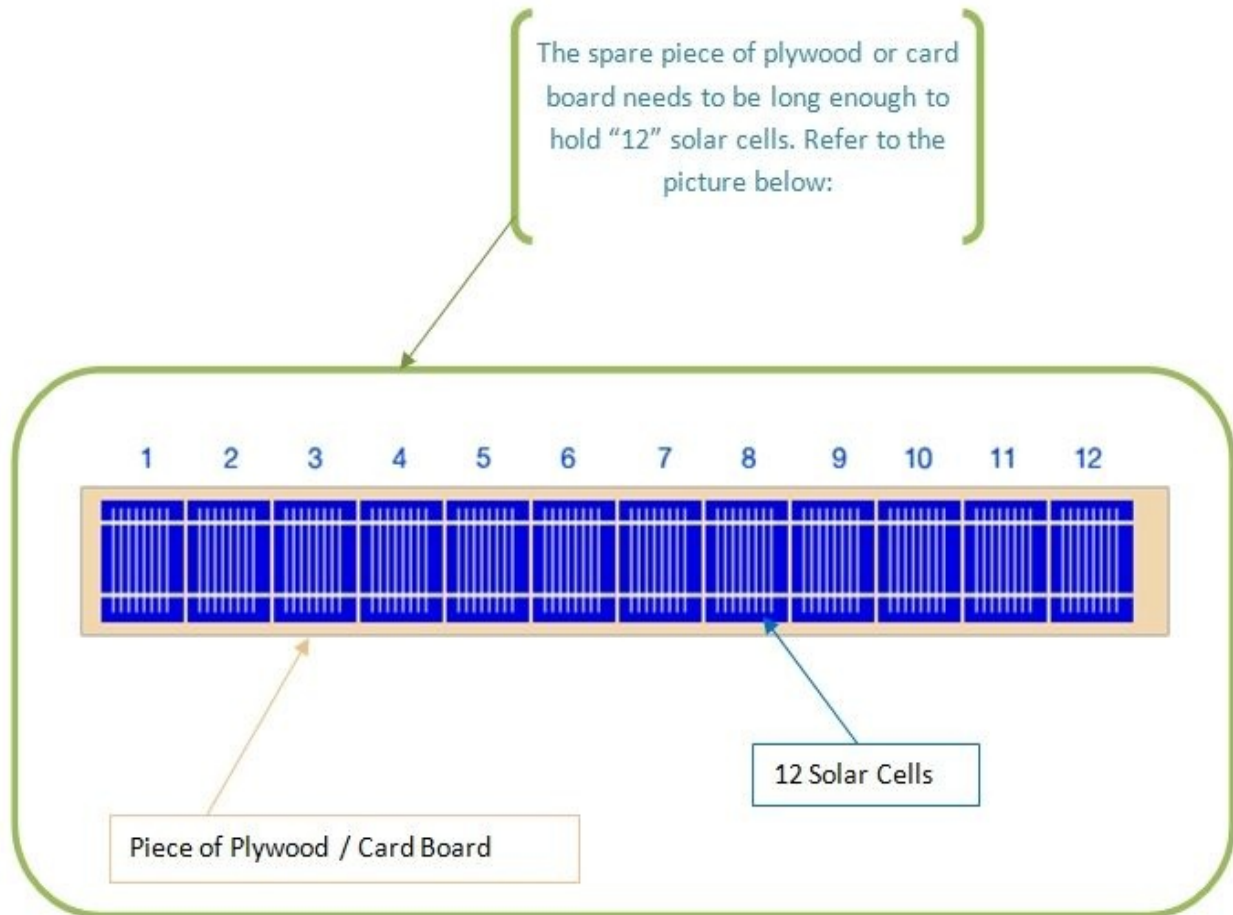

2. Cut your spare piece of plywood or card board long enough to fit 12 solar cells as seen in the picture on the previous page.

*Tip: If you are unsure about how long to cut your template, use a ruler to measure the size of one solar cell and multiply that number by 12. This will give you the length in inches depending on what units you are measuring in.

Example: If one solar cell is 5 inches wide, I would multiply 5 inches x 12 = 60 inches. So my template needs to be at least 60 inches long, and to be safe, I would make it 62 inches long.

For the width of the template, simply measure the width of one solar cell and make the necessary marks on your template to assist you while you saw.

3. Once you have completed cutting your piece of plywood or card board to

the right dimensions for your template, place the solar cell near the end of the template. Next, position the solar cell so that it is evenly facing the end of the template. Refer to the picture below:



Once the solar cell appears to be even with the template, take a pencil and trace around the solar cell. Be careful not to place any pressure on the solar cell to prevent from damaging the cell.

*Tip: Most eBay sellers ship solar cells with a piece of card board the same size or close to the same size as the solar cells. I recommend either using the piece of card board shipped with your solar cells, or create your own. This way you will not have to worry about damaging your solar cell.

After you have traced the solar cell, move the solar cell in front of the traced out solar cell. Leave about $\frac{1}{4}$ of an inch between the solar cell and the traced out solar cell, and begin to trace around the solar cell in it's new position again. Repeat this process until you have successfully traced out 12 solar cell blocks. Refer to the picture below:

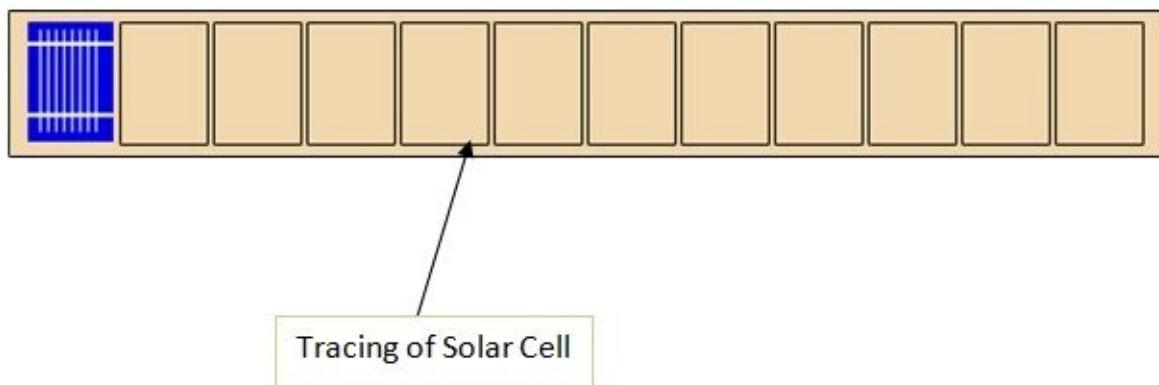

4. Next, take the tile spacers and place one on each side of the traced out solar cell within the $\frac{1}{4}$ of an inch space. Refer to the picture below. Use the staple gun or stapler to pin the tile spacers in place.

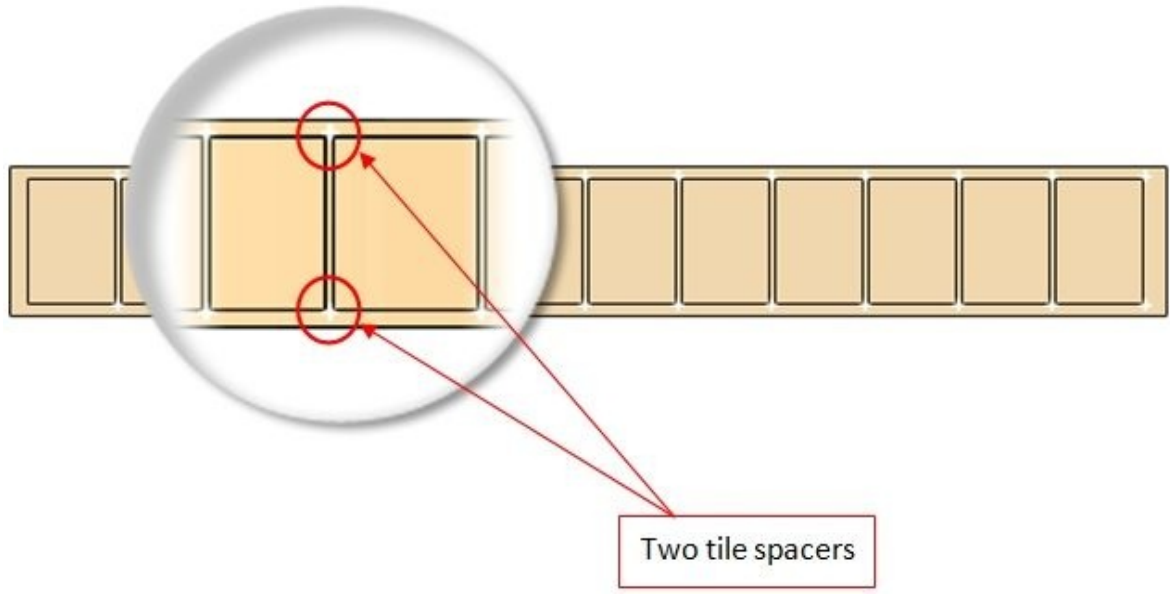

Using the tile spacers will allow you to easily keep all your solar cells evenly aligned. As a result, the tile spacers help to create a more professional look.

Soldering The Solar Cells Together

After you have finished creating your template, you can start assembling the solar cells together. Before you begin that step, for those who may not know, the **top** of most solar cells is the “**negative (-) side**”, and the **bottom** of most solar cells is the “**positive (+) side**”.

The next piece of important information you need to know is, for this solar panel, you will be hooking up your solar cells in series. For those of you who may not know what a series connection is, refer to the following definition and the visual example below:

Series Connection: *Electrical connection where the positive terminal of one device is attached to the negative terminal of the next in a series string.*

Series Connection: *Electrical connection where the positive terminal of one device is attached to the negative terminal of the next in a series string.*

Example:

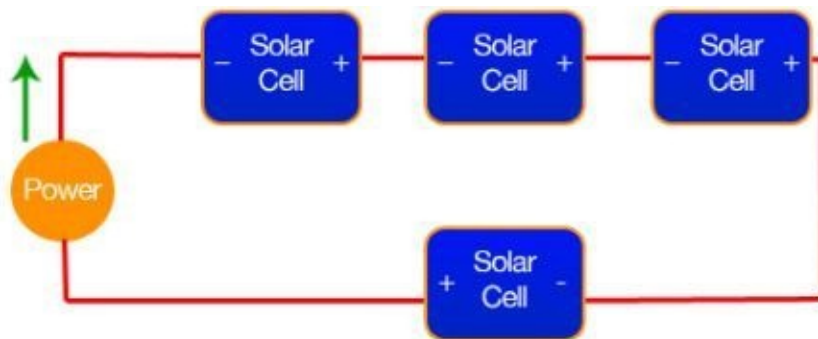

In the circuit you can notice that each component is going in the following continuous sequence:

+ TO - TO + TO - TO + TO - TO + TO - ... and this sequence continues to repeat

Hooking your solar cells in series will increase the voltage output for your solar panel, allowing you to successfully charge a 12 volt car battery if needed.

So now I have covered some of the fundamentals needed to assemble solar cells in series. You can now begin the assembling process.

*Tip: While assembling or working with the solar cells, wear either some latex or vinyl gloves to prevent damaging your solar cells as well as burning yourself while dealing with the soldering process.

5. *Tip: Before you begin assembling your solar cells, you can find solar cell kits that already have the solar cells pre-tabbed. Pre-tabbed solar cells are simply solar cells that already have the tabbing wire on the solar cells. Most eBay sellers now days will sell you a kit with pre-tabbed solar cells. I **highly** recommend that you try to find a seller or store that sells pre-tabbed solar cells as this will save time on the assembly process. If you fall in this category of already containing a set of pre-tabbed solar cells, step the next step.

If your solar cell kit does not come pre-tabbed, you will have to solder the tabbing wire on each individual solar cell first before assembling the solar cells together. We will cover this in the next step.

6. If your solar cells are pre-tabbed, skip this step.

What you first want to do is, go ahead and plug-in your soldering iron so that can be warming up.

Next, before you start to solder the tabbing wire on the solar cells, you need to cut the right length of tabbing wire for your solar cells. Your individual tabbing wire strips need to be long enough to connect two solar cells together.

A trick to achieving this is to place two solar cells (one in front of the other) on the template that you made. Then take the roll of tabbing wire and roll out enough to where it is the length of the two solar cells on the template. Once you have rolled out the right length and have your cutting mark, go ahead and cut the piece of tabbing wire. After you cut the first strip of tabbing wire, go ahead and use that one strip to cut the rest of the tabbing

wire on the roll to the same exact length.

Refer to the image below for more guidance:

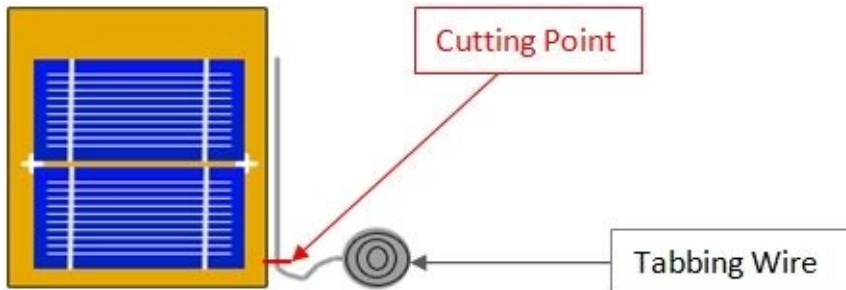

7. After you have completely finished cutting your strips of tabbing wire, you can begin to solder the strips of tabbing wire on each individual solar cell.

1. Take one solar cell and place it on your working area where the positive side is pointing back at you. The positive side usually consists of small white squares. Refer to the image below:



2. Next, take two strips of tabbing wire and lay them to the side of the solar cell for now. Take your Rosin Flux Pen and add one layer of flux from the pen to each white square on the solar cell.

3. Now take one of your strips of tabbing wire and position it to where it is covering all the white squares on one side of the solar cell.

*FYI: Depending on the type of solar cell you are using, you may have 2 columns of white squares (3 per side for 3x6 Evergreen solar cells) or just 1

column of white squares. If you have 2 columns of white squares as seen in the image below, each column will receive its own strip of tabbing wire. Of course if you only have one column of white squares, you will only need one strip of tabbing wire for this side of the solar cell. Refer to the image below:

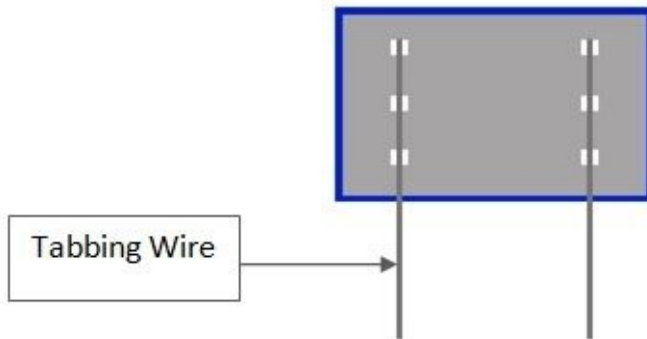

4. Once you have positioned the tabbing wire where it is over each white square on one column, you can start to solder the tabbing wire in place. The only places you need to solder are those where the tabbing wire meets the white squares.

*Tip: Be sure to read your soldering iron's instruction manual about how to properly use the soldering iron. You can also usually visit Google.com and search for, "how to solder solar cells", to find great examples and information on how to properly use a soldering iron.

*FYI: If the case arises where you are having a difficult time getting the tabbing wire to bond to the solar cell, feel free to add solder on top of the white squares before placing the tabbing wire on top of the 3 white squares.

5. Once you have successfully soldered one strip of tabbing wire to one column, follow the same steps for the second column. Of course if your solar cells have only one column of white squares, you can skip this step. As a final result, your solar cell should contain two strips of tabbing wire as seen in the image below:

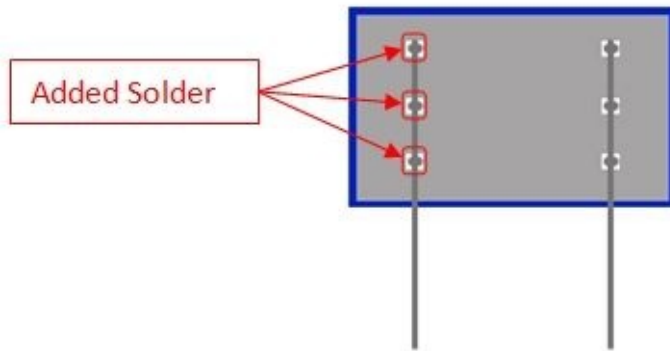

6. After you have completed soldering the tabbing wire on the first solar cell, proceed to the next solar cell and repeat the process above. Go ahead and repeat the process for all 36 solar cells before attempting to move to the next step.

*Tip: If you are new to soldering, be aware that this process can be time consuming, but after you get the hang of it, it will become easier as you move along.

This step involves soldering 12 solar cells in a row using the template you made as seen in the pictures on the previous pages. At this point, you should have 36 solar cells with tabbing wire on each individual solar cell.

1. Place 1 solar cell at the starting end of the template, and place another solar directly in front of it on the template. Take the tabbing wire from the first solar cell, and place tabbing wire on top of the second solar cell. Refer to the image below:

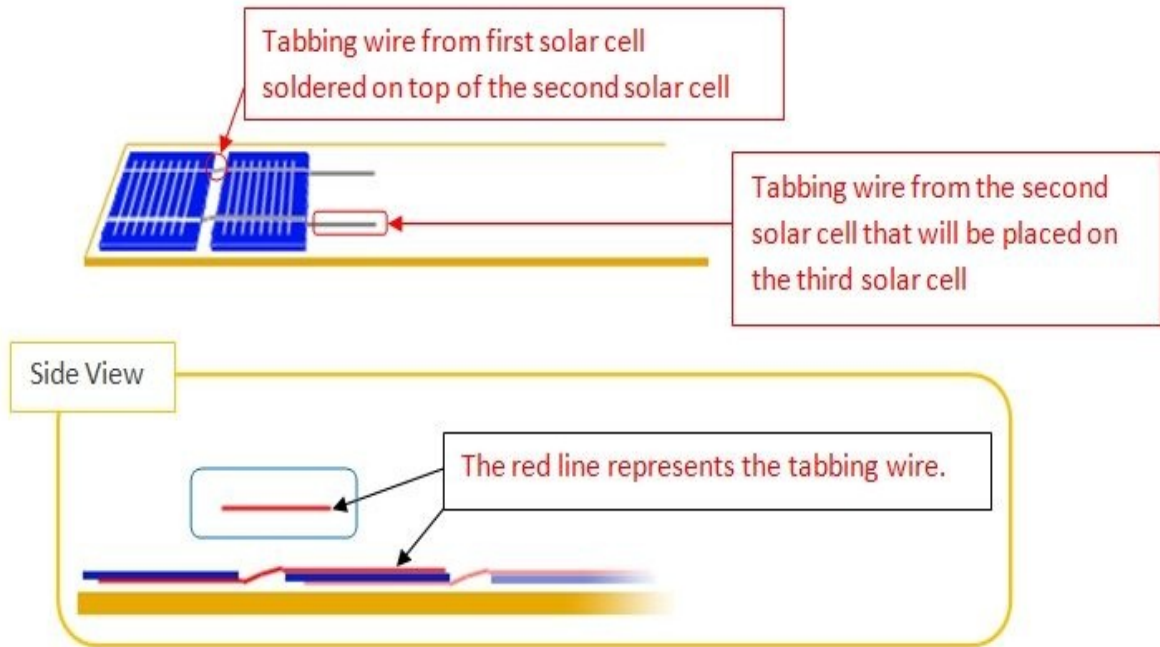

2. After you have positioned the tabbing wires from the first solar cell over the second solar cell, take your Rosin Flux Pen and gently apply one layer of the flux on top of the two thick white lines on the second solar cell.

3. Next, take your soldering iron and begin to solder the tabbing wires down directly on top of the thick white lines on the second solar cell. Refer to the image above:

4. After you have successfully soldered down both pieces of tabbing wire from the first solar cell on top of the second solar cell, add another solar cell in front of the second solar cell. Repeat the same process as before with the first two solar cells, except this time, take the tabbing wires from the second solar cell and solder on top of the third solar cell.

*Tip: It is wise to check with a digital multimeter that you are producing the right amount of voltage after you solder together an additional solar cell.



How to Determine How Many Volts Two or More Solar Cells Should Produce

Your supplier should tell you how many volts each solar cell produces, as well as the watts and amps. However, for this step you are only worried about the volts.

Once you know how many volts your solar cell produces, the rest is very simple about how to determine exactly how many volts you should be receiving.

Since you are hooking up your solar cells in series, you add the volts.

Example: If your solar cells are rated for .5 volts (v) each, and you solder 2 solar cells together, you are now producing 1 volt ($.5v + .5v = 1v$). If you have 3 solar cells soldered together, you will be producing 1.5 volts ($.5v + .5v + .5v = 1.5v$).

So of course after soldering 12 solar cells together on your template, after testing the output voltage for that entire string (a column of solar cells connected together) of solar cells, you should be producing 6 volts ($12 \text{ (solar cells)} \times .5v = 6 \text{ volts}$).

Refer to the image below on how to properly check the voltage of two or more solar cells hooked up in series:

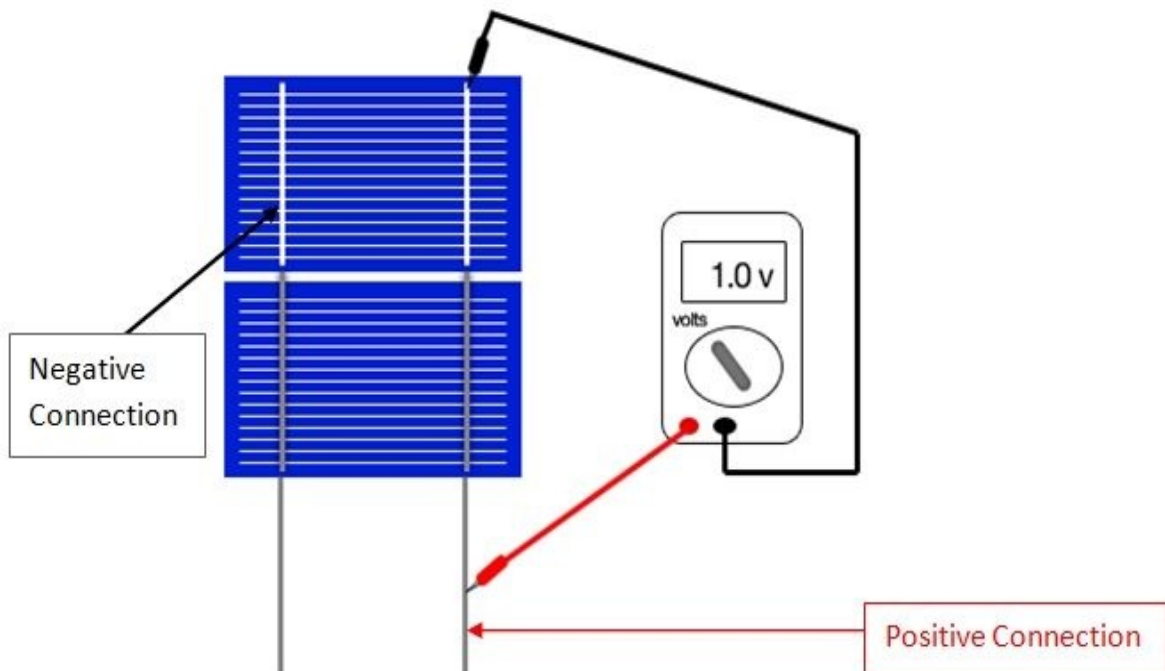

5. Continue to repeat the process until you have 12 solar cells correctly bonded together on your template. After you finish one string of solar cells, always check to see how many volts you are producing. It's better to fix an issue this early in the process than wait until the end.

6. After checking the voltage output of the first string of solar cells, repeat the entire process and create 2 more strings consisting of 12 solar cells connected in series. So simply repeat this process from step 1-5 to create 2 more strings of solar cells. Refer to the image below on how your finished strings of solar cells should look:

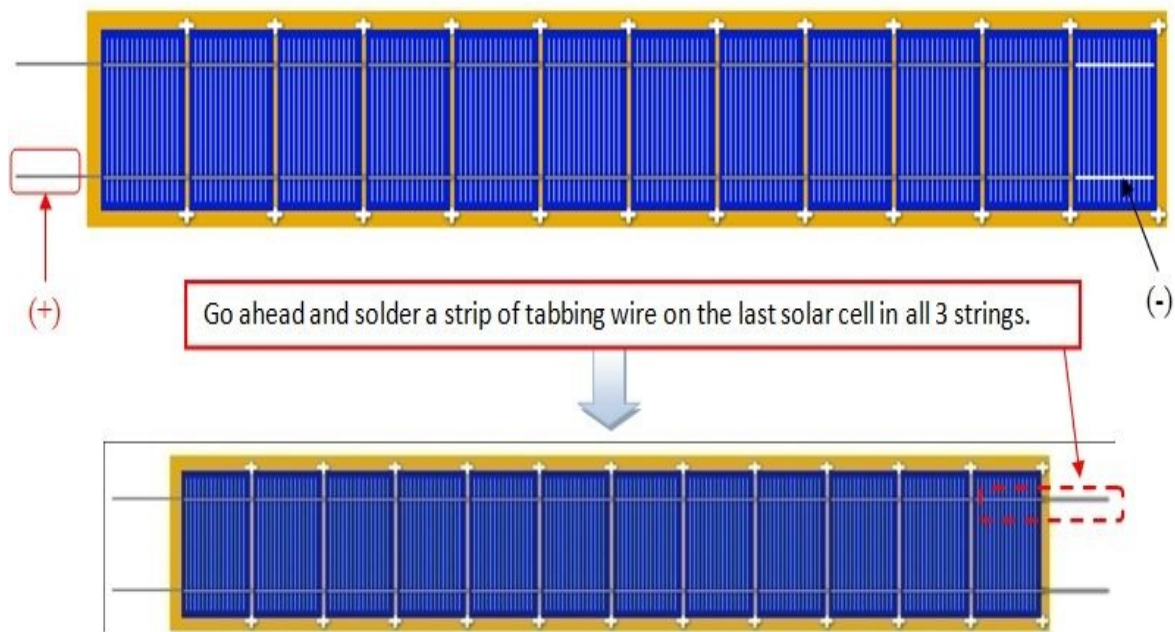

Step 3

Placing the Solar Cells in the Frame

We finally have come to the step where things start to fall in place to where you can start to see the solar panel come together.

1. The items you will need for this step are as follows:

- Bus Wire
- Soldering Iron
- Solder
- Tile Spacers
- Transparent Silicone
- Caulk Gun

2. At this point, you should have 3 strings of solar cells correctly soldered together in series. You should also by this point have assembled a 2x4 painted frame that has a sheet of painted pegboard screwed inside the body of the frame.

1. For this step you will be working with the frame and solar cells. Place your frame on your working station.

2. Take one string of solar cells and place inside the frame.

*Tip: If you soldered your solar cells correctly, you should be able to lift your entire string of solar cells by gently grabbing both ends and lightly laying the string inside the frame. If needed, have someone assist you while moving the solar cells from your working area to inside the frame. If the case comes about where 1 or 2 of your solar cell connections (tabbing wires) disconnect, simply continue to place the string inside the frame, and re-solder any loose or broken connections.

Once you have successfully placed one string of solar cells inside the frame, repeat the process until you have placed all 3 strings of solar cells inside the frame side by side.

3. Next you need to evenly organize your strings of solar cells inside the frame. An easy way to achieve this is by taking advantage of the tile spacers and the pegboard.

What you first want to do is find a starting point for your first string of solar cells. Since the pegboard consist of linear lines of holes, simply decide which line of holes you would like to align your 1st string of solar cells against. For the 2nd string of solar cells, apply the same concept, however, provide about 1 centimeter of space between the first string of solar cells and the second string of solar cells. Apply the same concept one last time for the 3rd string of solar cells.

Refer to the image below on how to properly align all the strings of solar cells:

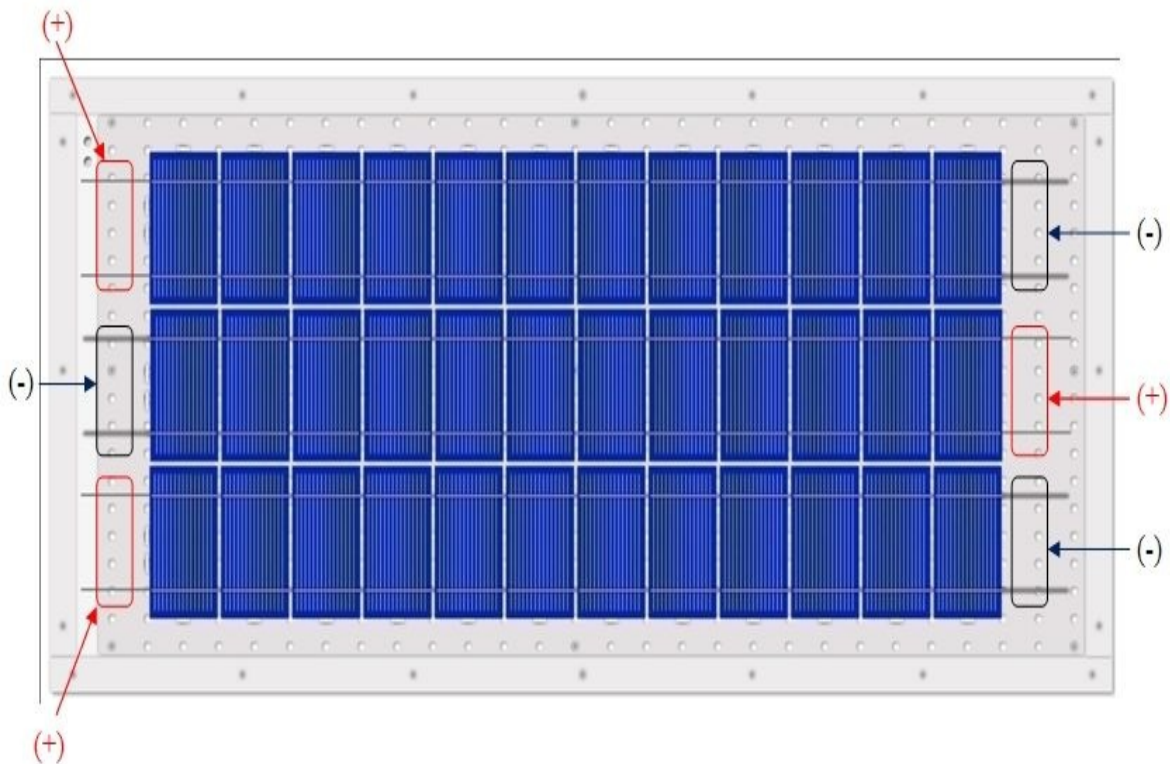

*Tip: If you need to, mark lightly with a pencil the starting point of each string of solar cells. This will help you position the string back in place

once you finish the following procedures to come.

3. Now that you have properly aligned all your strings of solar cells, you can begin to glue the solar cells down to the frame with the transparent silicone.

1. Go ahead and place your silicone tube inside your caulk gun and cut the tip of the silicone tube. Be sure to cut your slit at the end of the silicone tube at an angle as seen in the image below:

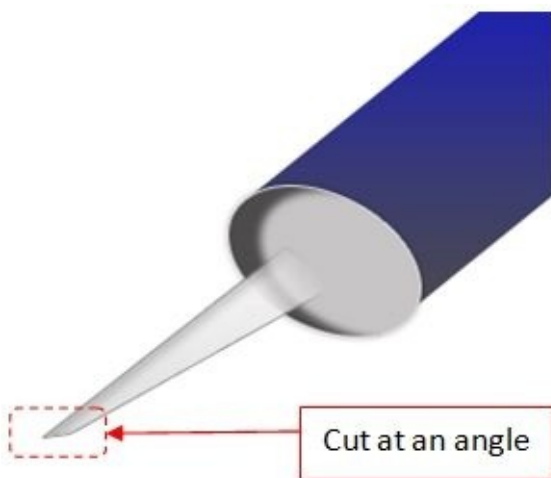

2. Next you need to place tile spacers at one end of your strings of solar cells so that when you are gluing your strings of solar cells down, they will remain even. Refer to the image below:

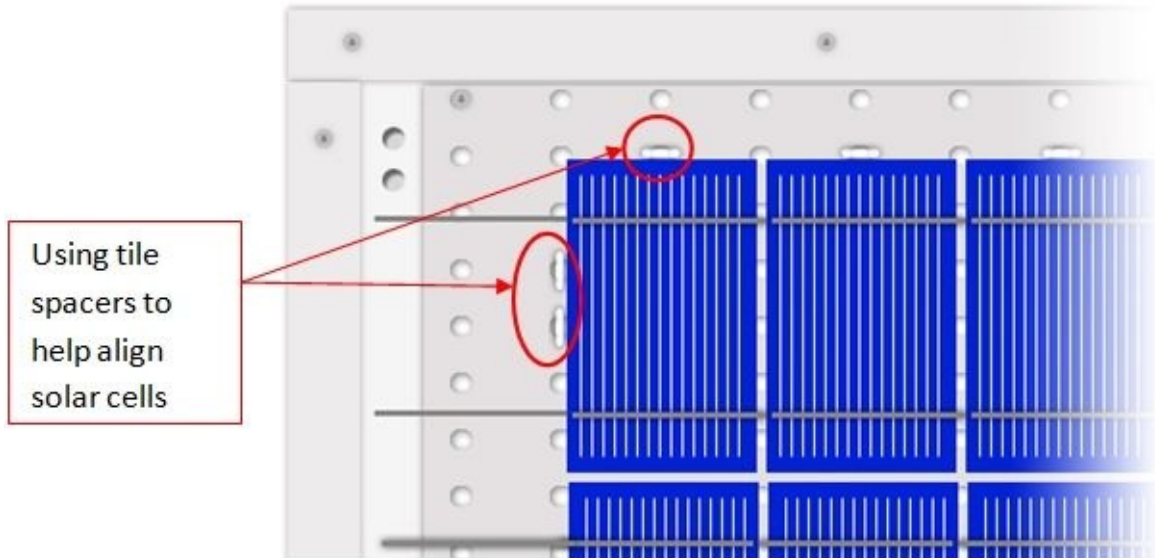

3. Once your tile spacers are in place, gently lift up the first solar cell in the first string of solar cells, and apply a quarter size of amount of silicone beneath it. After applying the small amount of silicone underneath the first solar cell in the first string of solar cells, proceed to the next solar cell in the first string of solar cells and repeat the process. Continue this process until you have applied a quarter size amount of silicone under every solar cell in the first string of solar cells. Refer to the image below for an example of how much silicone to place under each solar cell:

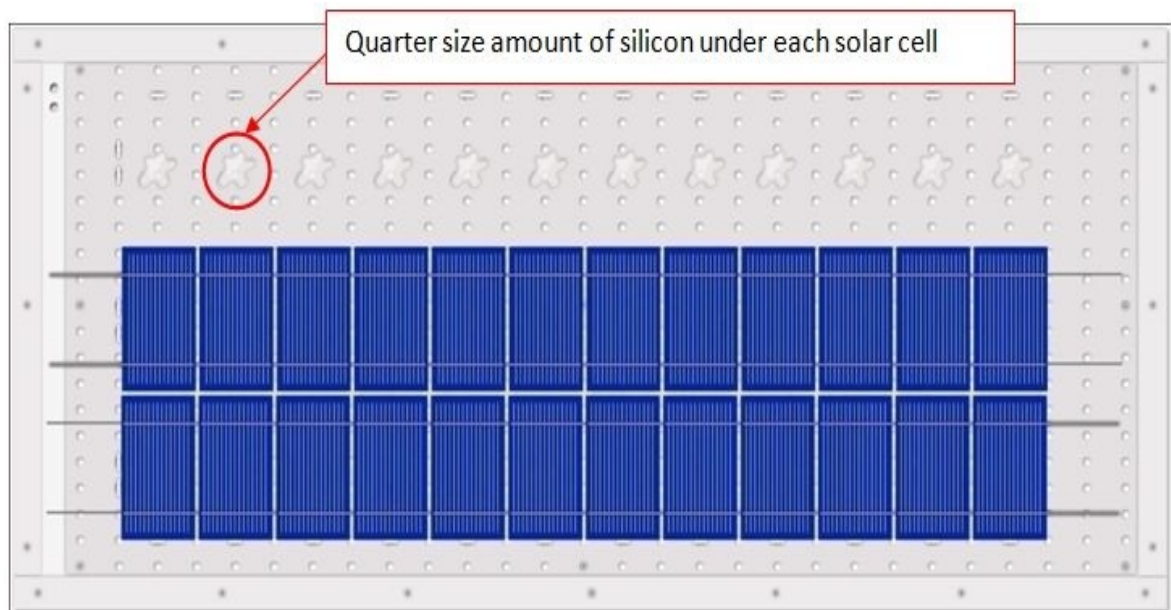

4. Next, take a few more tile spacers and place them to the left side of solar cells in the first string of solar cells. Refer to the image below:

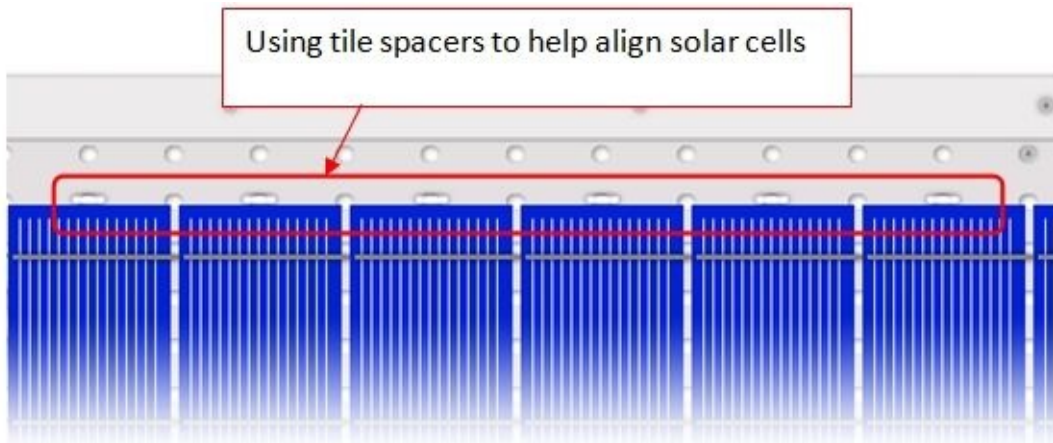

5. After placing the tile spacers to the left of the solar cells in the first string of solar cells, gently slide the solar cells up against the tile spacers. This will ensure that your string of solar cells is evenly aligned in the frame. The silicone takes a while to completely dry, so the solar cells should slide over fairly easy.

After you have successfully aligned the first string of solar cells against the tile spacers, repeat this entire process for the next two strings of solar cells.

*Tip: Once all your solar cells are glued down to the pegboard and evenly aligned, leave the tile spacers inside the frame that are helping to keep your solar cells evenly aligned. Allow time for the silicone to completely dry before removing the tile spacers.

4. While your silicone is still in the process of drying, you can start soldering your strings of solar cells together.

The way you need to connect your strings of solar cells are in series. An easy way to determine which end of the string is the negative connection and which end is the positive connection is, whichever end has the strips of tabbing wire sticking out from below the solar cell is the **positive** end. Whichever end has strips of **tabbing wire sticking** out from **above the solar cell is the negative** end.

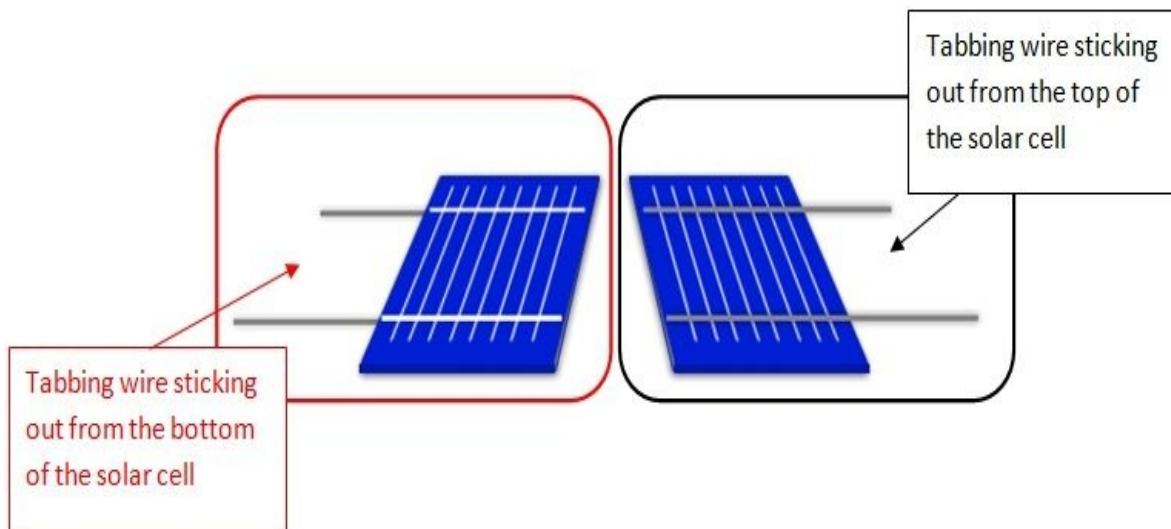

Basically, you can think of one string of solar cells as one huge solar cell. There is only 1 positive end, and there is only 1 negative end. So the same way you hooked up your solar cells in series, you are going to apply the same concept to the strings of solar cells.

1. Connect the negative end of the 1st string to the positive end of the 2nd string with a piece of bus wire (the wire that is a bit wider & thicker than the tabbing wire).

*FYI: To correctly solder two strings of solar cells together with bus wire, **you will have to use solder**. Simply place the bus wire either on the top of the tabbing wire or beneath the tabbing wire and apply some solder to both wires to bond both together.

I highly recommend following along with the preceding images to get an idea where you should place bus wire, and which strings connect to another string. Another piece of information you should be aware of if you are completely new to solar panels is, after you connect all the strings together you can think of it as one huge solar cell. Again, there will be a positive end, and a negative end. Also, do not forget to check the amount of volts you are outputting after you connect 1 string to another string.

2. Refer to the following sequence of images below for the correct method on how your bus wires should be connected:

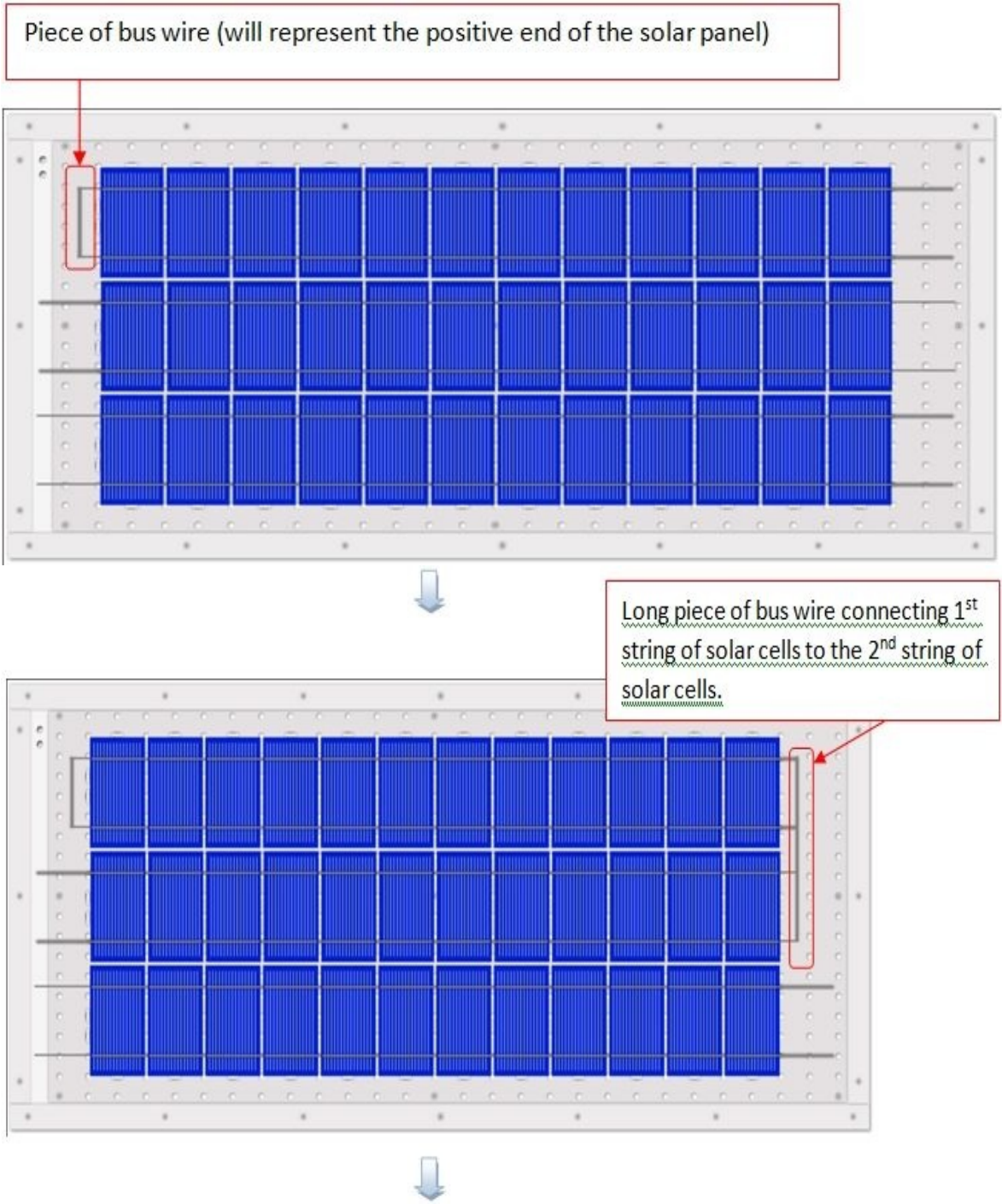

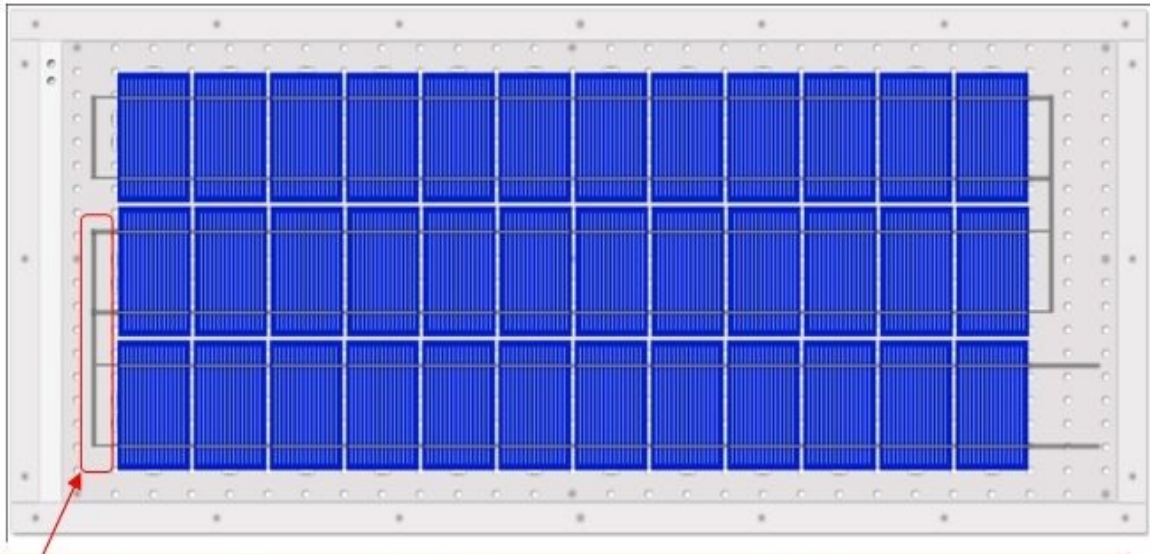

Long piece of bus wire connecting 2nd string of solar cells to the 3rd string of solar cells

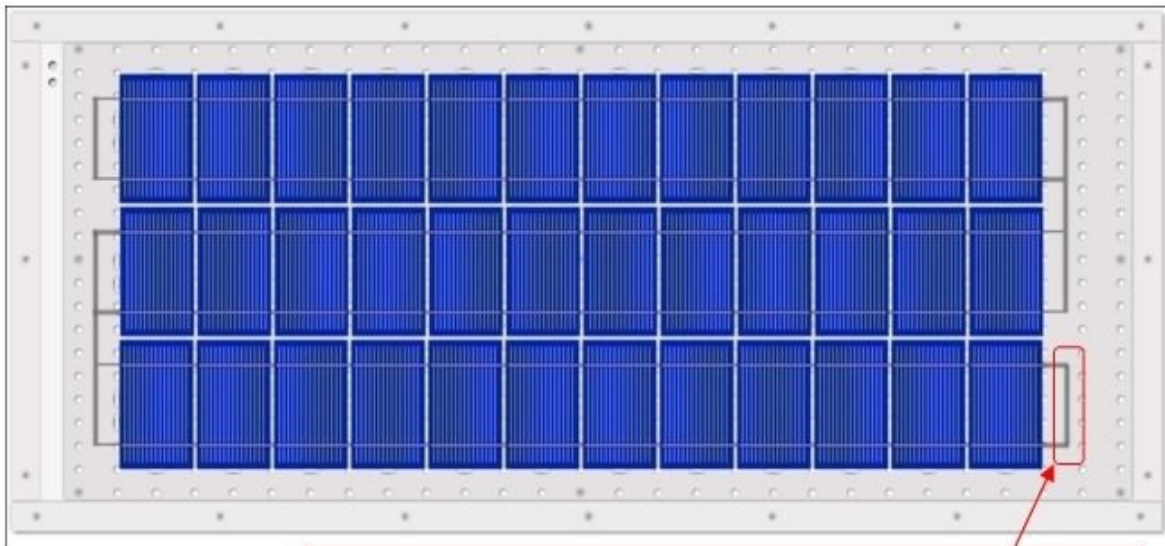

Piece of bus wire (will be the negative end of the solar panel)

5. After soldering the bus wires in place, you will need to route the negative end back to the two holes you drilled into the frame in Step 1. To achieve this, you will need to take a longer piece of bus wire and solder it to the negative end and run that bus wire back to the two holes. The positive end of the solar panel should be right in front of the two holes. So you will only need a small piece of bus wire to run the positive end to the two holes. Refer to the image below:

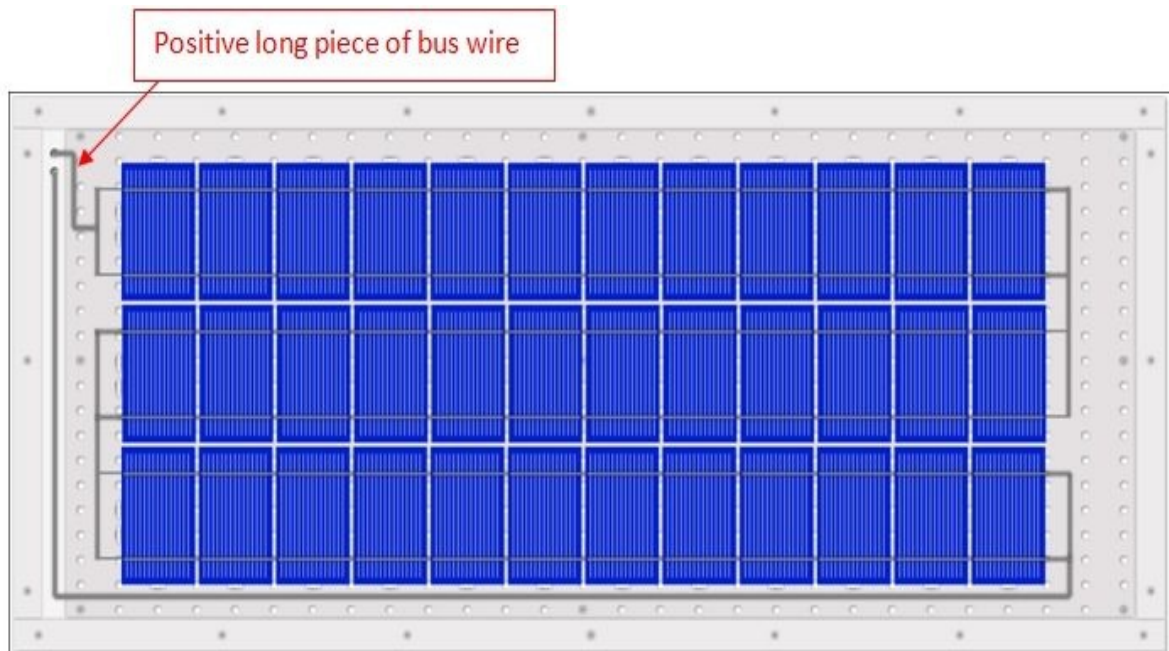
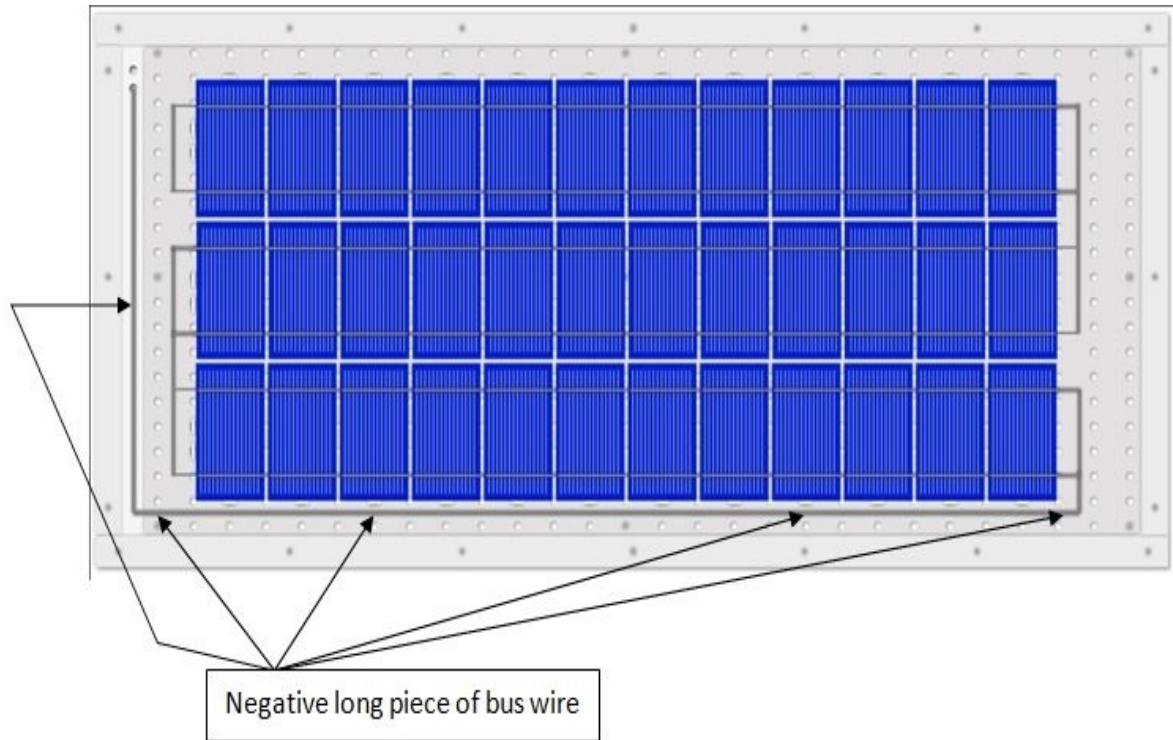

*FYI: Be sure to run about 4 ½ inches of bus wire through both holes in the

frame. You will be using this extra wire later on in the building process. Refer to the picture below:

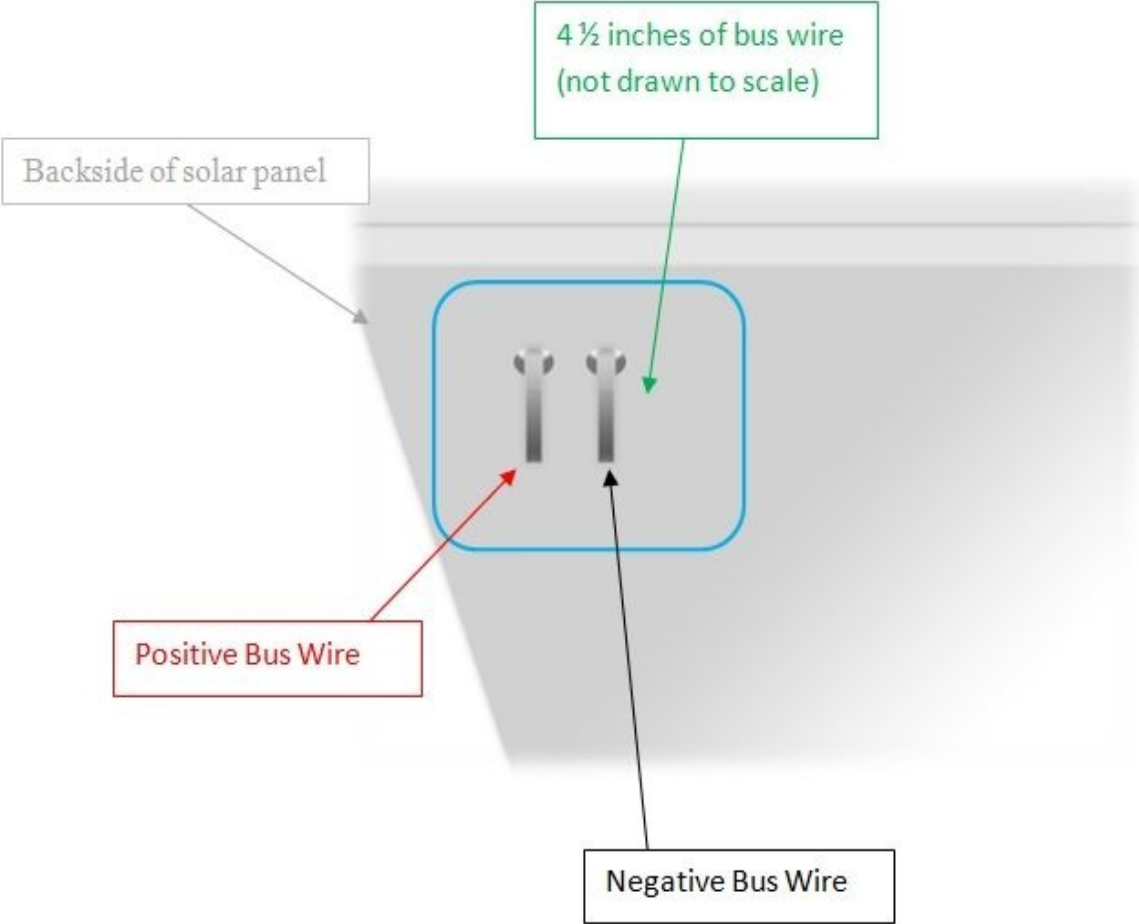

Step 4

Applying Slygard 184

Before we get started applying this application, it is wise to understand why we are using a liquid solution called Slygard 184. Slygard 184 is a encapsulating product that will help to protect our solar cells from water damage, internal moisture, and more. Basically, Slygard 184 is going to add an extra level of protection for our solar cells, and this will increase the life span for our solar panel.

The items you will need for this step are as follows:

1. The items you will need for this step are as follows:

- Slygard 184 (amount may vary per person)
- Internet Access

2. For this step I have found that it is easier for most individuals to learn from watching someone else apply the Slygard 184 rather than reading about it or looking at pictures. The way I learned most of what I know about building solar panels is from watching countless online solar videos. So instead of spending countless hours creating photos for each step of the process, I decided to refer you to a few videos that explain and show the correct method for applying the Slygard 184 solution. The link to the video below is a **free** YouTube video and was created by a very knowledgeable individual name Mark.



Link to video: <http://www.youtube.com/watch?v=6mdBnIt0xIQ> (Click the image above or copy and paste the link to the left in your browser to view the video)

Note: In the video Mark has his solar panel's back side exposed and he

applies the silicone to the backside of the solar cells. At this point in our process we obviously do not have access to the backside of the solar cells anymore. Instead, pour the Slygard 184 solution on top of the solar cells. Either method (Mark's method or our current method) will be just fine. The goal here is to ensure each solar cell is covered with the Slygard 184 solution. As I mentioned at the beginning of this how-to guide, there are many ways to build a solar panel.

3. After you have applied the Slygard 184 solution over all the solar cells, and after the solution has completely hardened, proceed to the next step.

Step 5

Installing the Plexiglass on the Frame

Mounting the plexiglass on top of the frame is where you really start to see your solar panel come alive.

1. The items you will need for this step are as follows:

- 2x4 Sheet of Plexiglass
- 4 Hole Straight Brackets
- 4 Hole L Brackets
- Power Drill
- Drill Bit
- 1 inch screws (made for pressure treated plywood)
- Transparent Silicone
- Caulk Gun

2. 1. To get started, place the plexiglass somewhere near your working area.

2. Take all remaining tile spacers in the frame out. Next, apply 2 full lines of silicone around the edges of the frame. Refer to the image below:

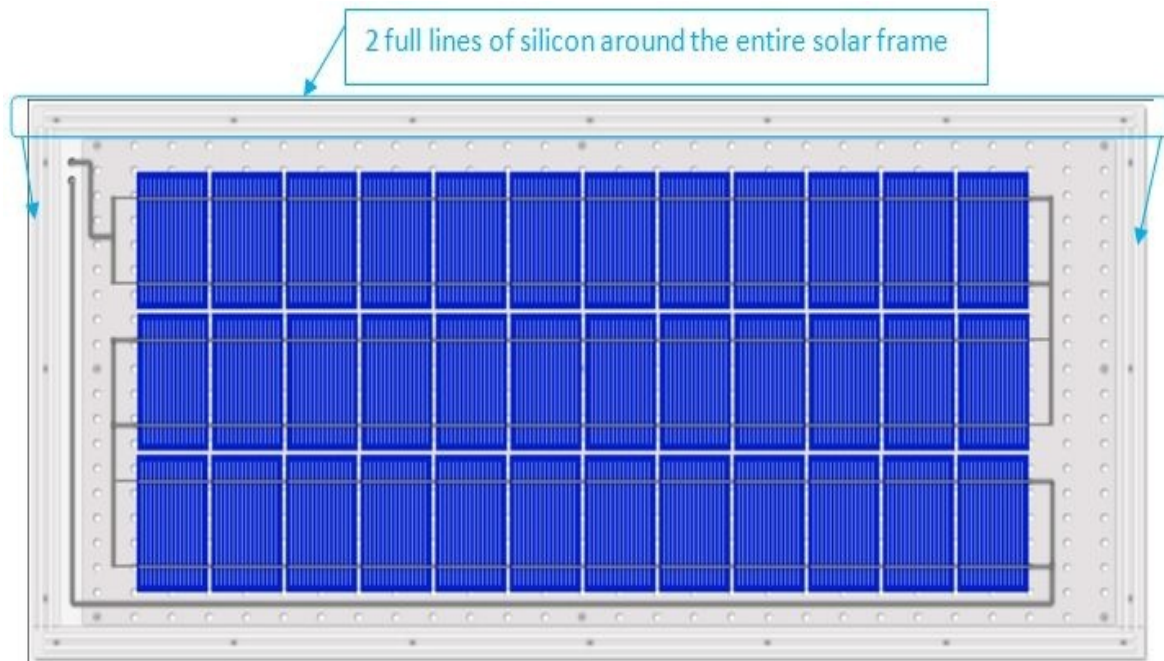
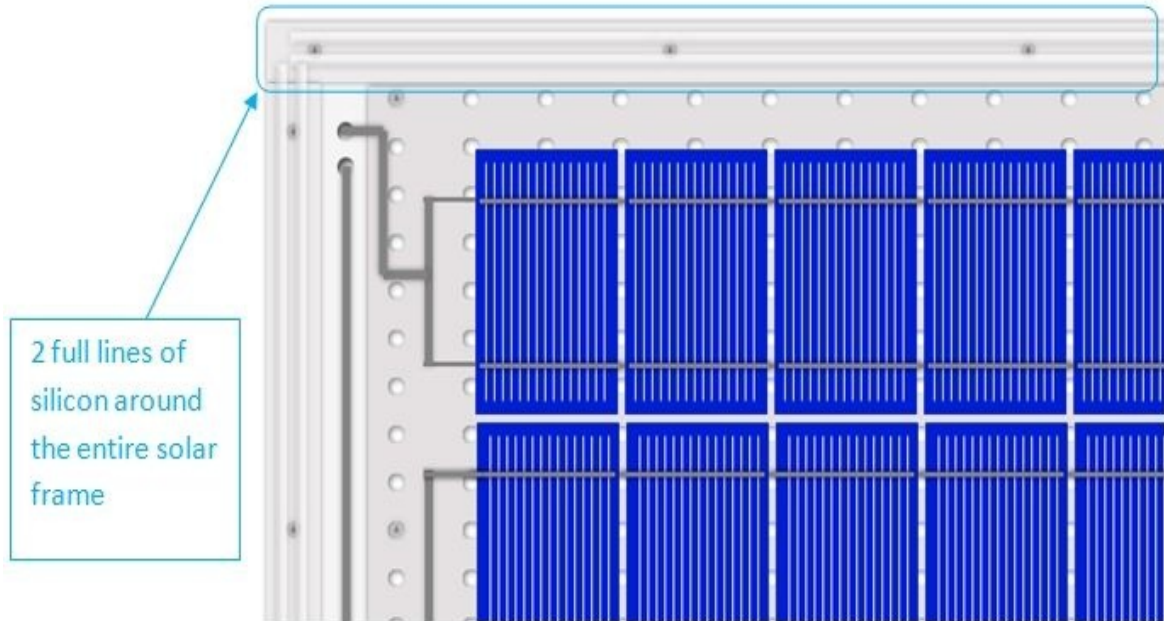

Immediately after applying the silicone to the outer edge of the frame, take the plexiglass and place it directly over the entire frame. Be sure that your plexiglass is as even as possible over your entire frame.

3. Take your straight brackets and L brackets and position them side by side around the top of the plexiglass. Using your power drill, attach a drill bit

close to the size of the 1 inch screws and begin to pre-drill all your needed holes inside the brackets.

*Tip: While pre-drilling your holes, drill at a slow rate to prevent from cracking your plexiglass. Drill far enough to where you drill pass the plexiglass into the outer pieces of plywood.

Refer to image on the following page:

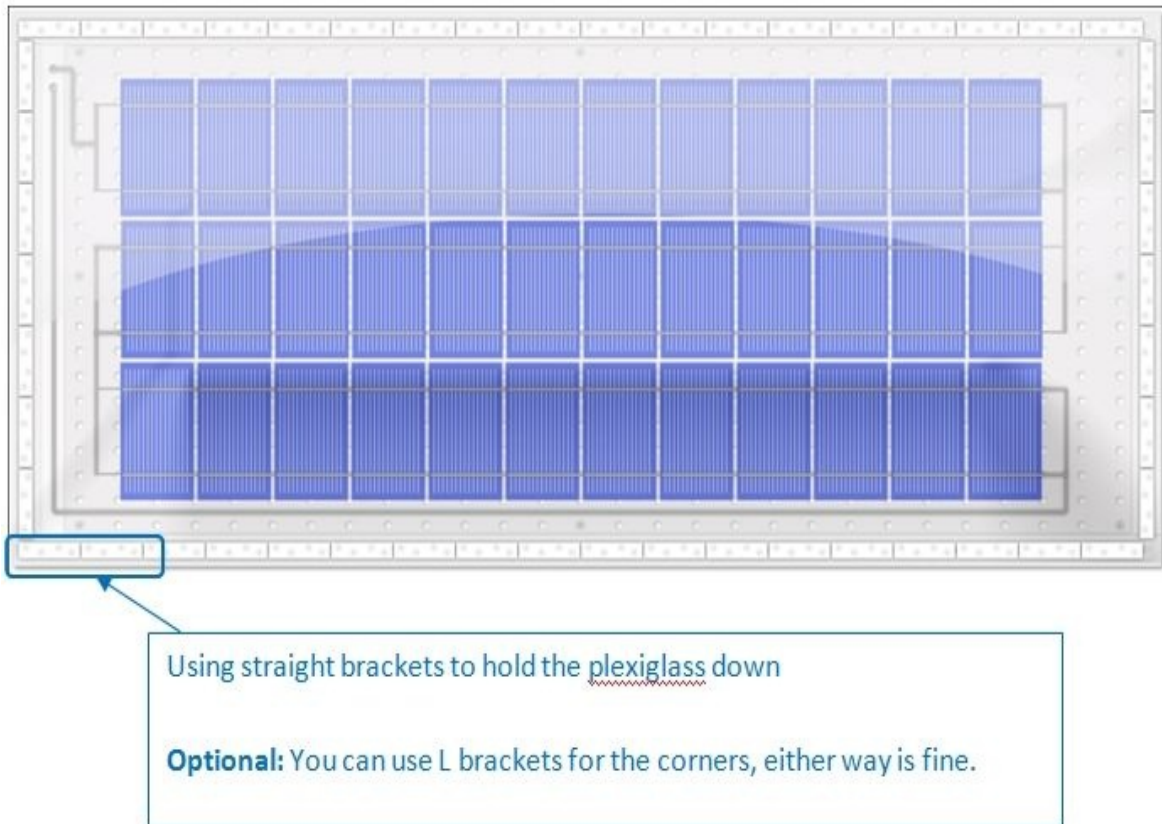

4. After pre-drilling your holes, you can begin to screw in your 1 inch screws. I would recommend that you first start the screw by manually screwing it down into pre-drilled hole and then finishing up with the power drill. While using the power drill, continue to screw at a slow pace. Screwing too fast and screwing too tightly could result to cracking the plexiglass.

5. Once you have successfully screwed in all your screws into the plexiglass, take any leftover silicone and apply silicone around the perimeter of the entire frame. Try to apply silicone in areas where there

may be gaps of any kind where water could easily enter your solar panel.

Step 6

Installing the Junction Box

The junction box is very important as it helps secure your connections from the outside of the solar panel. It also provides an easy way for you to connect and disconnect the solar panel from other devices. Overall, it adds a professional look to your entire solar panel. For those that may not know, a junction box is placed on the backside of the solar panel.

You can usually find a junction box for a solar panel on eBay fairly cheap.

1. The items you will need for this step are as follows:

- Solar Panel Junction Box
- Power Drill
- Drill Bit
- Soldering Iron
- Solder
- ½ inch screws (made for pressure treated plywood)
- Transparent Silicone
- Caulk Gun

2. Junction boxes come in all types and sizes. It's a great idea to find a junction box that has a blocking diode (prevents the backflow of current) already installed inside the junction box. For your solar panel, you can get by with a small junction box. One that is just wide enough to cover completely the two holes you drilled into the frame.

3. For the two pieces of bus wires that you placed inside the two holes in **Step 3**, make a quick note about which wire is positive, and which wire is negative.

Some junction boxes come with wires and leads already installed which is what I recommend you try to find on eBay. They will have the leads labeled as positive or negative. Depending on the type of junction box you purchase, most junction boxes will allow you to easily slide the bus wire

from the solar panel inside the slot in the junction box. After doing so, it would be wise to solder the leads from the junction box to the bus wires that are underneath the slot.

4. All solar junction boxes have the same concept on how to connect them to your solar panel and mount them on the backside of your solar panel. So I will just give a general overview of what you need to do to successfully install a junction box. If you are un-experienced with working with junction boxes, I would also recommend asking your supplier the proper way to install the junction box just for an additional reference.

5. 1. After connecting the leads (positive/negative bus wires) from the solar panel to the junction box, hook up your digital multimeter's leads to the junction boxes leads to ensure you are receiving the correct voltage. Next, before soldering anything, find a place in your junction box, usually the center, where you can pre-drill two holes (depending on the size of your junction box, you may need to drill more holes) to screw the junction box down to the frame. Make sure your junction box is completely covering the two holes you drilled into the frame in **Step 1**.

2. Once you have drilled your holes in the junction box, using a manual screwing method, screw in the necessary amount of ½ inch screws into the pre-drilled holes. Next use the power drill to tightly screw the screws into the junction box.

Your junction box should be sturdy and unable to move around once you have completed screwing in your screws. The two holes you drilled into the frame in **Step 1** should now be completely covered by the junction box.

6. Using your soldering iron, solder the internal leads from the junction box to the bus wires coming from the solar panel. Again, depending on the type of junction box you have, this process may differ, but you basically just want to make sure the bus wires are securely connected to the leads of the junction box.

7. Next, using your transparent silicone, fill in the two holes you drilled into

the frame in **Step 1** with the silicone. This will help ensure that no outside moisture or water will enter your frame from those two holes. The junction box should do a great job preventing this anyway, but as an extra precaution, it is better to enclose it with silicone. Also note that, the silicone itself will not harm your solar cells or bus wire, nor cause any power lost.

After filling in the holes with silicone, leave the junction box lid off until the silicone has completely dried.

8. While the silicone is drying inside the two holes, add silicone around the perimeter of the junction box. This will prevent any moisture or water from sliding underneath the junction box. The junction box should be fairly tight up against the frame from the screws, but adding silicone around the base of the junction box adds another layer of protection.

9. Once the silicone has dried inside the two holes, place the lid back over the junction box.

Next, flip your entire solar panel back over and check one final time with a digital multimeter that you are receiving the correct amount of voltage.

10. After checking your voltage output with the digital multimeter, if you have any leftover silicone, look one final time around your solar panel where you may need to apply extra silicone to prevent any moisture or water from entering your frame.

Once completed, you are finally finished with assembling a fully working solar panel.

Step 7

Learning About Solar Power System Components

After you have checked your solar panel to make sure it is outputting the correct voltage and amperage, you can pat yourself on the back as the hard part is over. The next two steps will explain how you can create your own solar power system in your home so that you can power everyday AC devices such as the following: cell phones, laptops, mp3 players, televisions, outside lighting, and more.

Before you begin building the solar power system, I need to go over some important information about the different components needed to create a solar power system.

To create a very basic solar power system you only need 3 primary components:

- Charge Controller
- Deep Cycle Battery
- Inverter

Charge Controller: *A charge controller maintains current from your solar panels to your battery bank, and prevents your batteries from being over-charged as well as prevents the backflow of current into your solar panels.*

A charge controller could be considered the brains of your entire solar power system because it decides rather or not your battery needs to be charged any further. Another important feature is the backflow prevention. Whenever you have a battery involved in a system, you risk the possibility of current backflow which can damage your solar panel. In systems that do not have charge controllers, people use blocking diodes which sole purpose is to prevent the backflow of current. As I mentioned earlier, most junction boxes include blocking diodes, but if your charge controller already has this feature, you do not have to worry about rather or not your junction box has a blocking diode.

When searching for a charge controller, be sure to check to see if it has the two important features which are, preventing overcharging and preventing backflow of current. Not all charge controllers include the same features. Some charge controllers are built for more complex solar power systems, and then you have those that are built for smaller solar power systems. For the solar panel you built using this eBook, a basic charge controller will do.

As I stated before, there are charge controllers for large solar power systems, and those for small solar power systems. It is very important to know how many Amps your solar panel produces. Since you soldered together your solar cells in series, your amps will remain the same throughout the entire solar panel. If you are using the 3x6 Evergreen solar cells, that means your solar panel produces 3.5 Amps (A).

*FYI: You can usually find out how many amps your solar cells produce by visiting the manufacture website or checking the amps yourself while the solar cell is receiving direct sunlight.

So if your solar panel produces 3.5 Amps, it is wise to choose a charge controller that can handle 4 Amps or more. Depending on rather or not you wish to expand your solar panel system by adding more solar panels in the future will determine the type of charge controller you need. For starters, I recommend going with a simple charge controller that has the two important features above (prevent overcharging and backflow of current), and that can handle 4 Amps or more.

Recommended Charge Controllers:

Northern Tool + Equipment (northerntool.com)

At Northern Tool online store, you can find a very affordable charge controller to meet your needs. They have 1 basic charge controller that is capable of handling up to 7 Amps for under \$30.00.

In the search box at their website, type in the following keywords:

Solar Charge Controller 7 Amp

I have provided a picture of the charge controller on the following page for your convenience.

Keyword(s) or Item #

SEARCH

SHOP BY CATEGORY

SHOP BY BRAND

SHOP SALES + SPECIALS

CATALOG

STORE LOC

[Home](#) > [All Categories](#) > [Alternative + Renewable Energy](#) > [Solar Solutions](#) > [Charge Controllers](#) > Item# 336606

 [Recently Viewed](#)

 ▶ [VIEW MORE/LARGER IMAGES](#)

 ▶ [VIEW/SHARE CUSTOMER IMAGES](#)

Solar Charge Controller — 7 Amp

Protects batteries from overcharging and discharging, plus regulates the voltage when using 12V solar panels to charge batteries. For use with up to 105 Watts of solar power (one unit is good for up to 7 of Item# 339972). Must be used with all solar panels 10 Watts and higher. Weatherproof, so it can be used with all types of models and solar chargers, even wind generators.

 Overall Rating  4.5 / 5

53 of 57 would recommend this product to a friend.

[See all reviews below](#) [Write a review](#)

 Share this Product: 

Up To 30% Tax Credit Available

This product may qualify for special state, local, utility, or federal incentives that promote renewable energy and energy efficiency. Details at dsireusa.org

Item#: 336606

 Price: **Only \$29.99**
[Guaranteed Lowest Prices](#)



 Qty

Stock Status: In Stock*

Ship Weight: 1.0 lbs

[CALCULATE SHIPPING](#)

* Available to ship today. For store availability please contact your nearest [Northern store](#).

 [Add to Wish List](#)
 [Top Accessories](#)
 [Print Page](#)
 [Contact Us](#)
 [Email Product](#)

Screenshot taken of Northern Tool and Equipment Solar Charge Controller 7 Amp

*Tip: Before buying the charge controller from Northern Tool, I would suggest comparing prices with any similar models that may be listed on eBay.com. Many times you can find a cheaper deal for the same item on eBay.

Deep Cycle Battery: *A battery designed to keep a steady amount of current over a long period of time, and can be deeply discharged repeatedly unlike a standard car battery.*

The reason why solar power system owners choose to have Deep Cycle Batteries included in their design instead of standard car batteries is, deep cycle batteries allow you to continuously drain the battery without causing any damage to the battery. Standard car batteries are not made to be fully drained, but instead, made to give a car a quick boost and allow the alternator to take over afterwards.

Typically most devices that have an internal battery that is constantly being charged and then drained has a deep cycle battery.

Even though deep cycle batteries are made to handle constant discharging, it is not recommended in a solar power system to allow your battery to constantly become drained more than 60%-80%. Using that setup will extend the life of your battery. Most batteries last for years if properly maintained.

The typical 12 volt deep cycle battery can cost anywhere from \$80 on up. I personally would suggest visiting an automotive store to buy your 12 volt deep cycle battery, such as AutoZone, Pep Boys, or Walmarts that have automotive departments.

Charging a 12 volt Deep Cycle Battery:

In order to charge a 12 volt battery with a solar panel, your solar panel has to be producing at least 18 volts. Even though it is a 12 volt battery, to successfully charge the battery, you have to be producing more volts than what it is rated for.

The solar panel built using this eBook will produce 18 volts since you have 36 solar cells (rated at 0.5 volts each) hooked up in series ($0.5 \text{ volts} \times 36 = 18 \text{ volts}$).

Inverter: Device that converts direct current (DC) to alternating current (AC).

Solar panels produce direct current, but to power the standard device you may have in home such as a small television, laptop, or cell phone, you need a way to convert that energy to alternating current. Inverters provide the solution for converting direct current to alternating current.

Inverters come in all shapes and sizes. Depending on the amount of watts you will need to consume and the devices you wish to power will determine the type of inverter you need to purchase. There are generally two types of inverters to choose from. A modified-sine wave inverter is usually used for devices (laptop, cell phone, etc.) that consume a low amount of watts. Pure sine wave inverters are more expensive and are usually used in more complex solar power systems.

Most people that are not going to put a large demand on their inverter and those that are not using a specific device that needs a pure sine wave can get by with a standard inverter.

Modified-sine wave inverters can usually be purchased from most retail stores that have an electronic department or automotive department. You can find a decent inverter for \$30.00 that will provide enough watts to power small consumer electronics.

*Tip: Figure out before hand how many watts the devices you will be hooking up to your inverter consume. If you purchase an inverter that only has a maximum limit of producing 200 watts, and you power something that needs 300 watts, that inverter is not a good choice for you.

If you are unsure of how many watts your device/s uses, you can purchase a **Kill A Watt** meter off eBay for under \$20.00. A Kill A Watt meter allows you to directly plug-in your AC devices into the meter and the Kill A Watt meter will display how many watts the devices are using.

Step 8

Now that you have some basic knowledge of what all 3 components do, I will now explain to you how to hookup all the components together.

1. Depending on how many volts/amps you are producing and the distance from your battery to your solar panel will determine the wire size you need (American Wire Gauge - AWG).

*Tip: If you are unsure on the wire size that you need, I would recommend visiting Lowes or Home Depot and talking with an employee in the electric department what size wire is suitable for your condition. Be sure to measure the distance from your battery to your solar panel beforehand.

2. Take the positive and negative leads from your solar panel and connect them to the solar end of your charge controller. Your charge controller should have labeled which side is for the solar panel and which side is for the battery.

3. Next, roll out enough wire to make a connection from the battery side of the charge controller to the 12 volt battery. Once you have enough wire rolled out, you can then hook up your positive wire (red) from the battery side of the charge controller to the positive side of the 12 volt battery. Afterwards, apply the same concept for the negative wire (**black**).

4. Lastly, you need to hookup your inverter to the battery. The typical solar power system owner will have their inverter fairly close to the 12 volt battery. On the backside of the inverter, there are usually two leads (1 red (positive), 1 black (negative)) that will allow you to easily connect your wires.

Roll out enough wire to connect your battery to your inverter. Once you have enough wire rolled out, connect the positive wire to the positive

terminal of the battery, and connect the other side of the wire to the positive lead of the inverter. Apply the same concept for the negative wire as well.

5. Once you have completed the last step, you have now created your own solar power system. Your charge controller should indicate that it is receiving solar energy (depending on the time of the day and the type of charge controller you have) and that it is hooked up to the battery.

For most people I know it is extremely difficult to follow setup instructions without a visual, so I have provided below a diagram of how you should have all 3 components hooked up to each other:

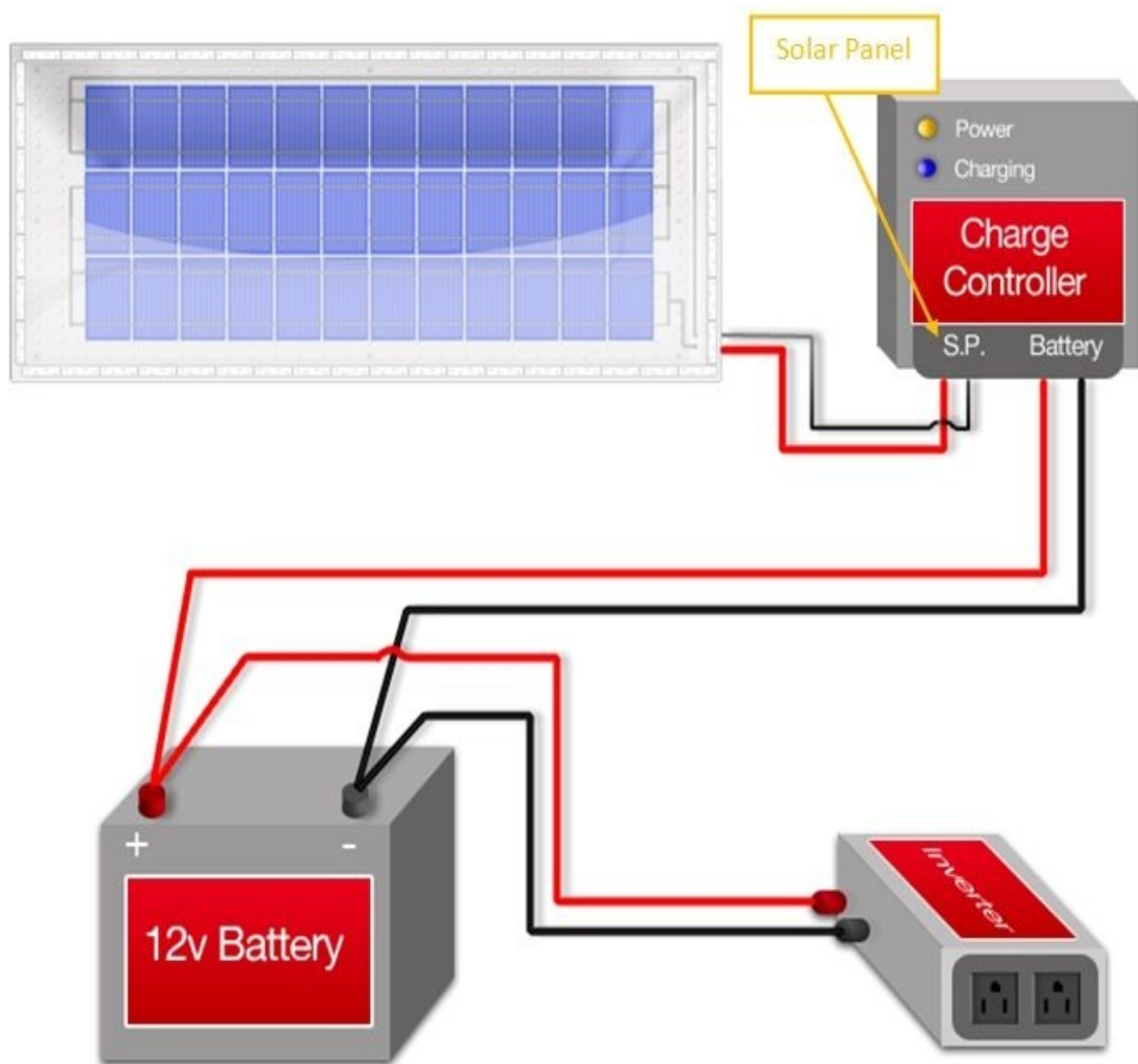

Step 9

Mounting The Solar Panel On A Roof

There are several ways to mount a solar panel on a roof, just like there are many ways to build a solar panel. The solar panel that you are building using the method I have explained in this eBook was mounted to the roof of a shed. The shed I used had a similar roof to that of a house, thus making it an ideal place to put the solar panel. This step will vary for most, so depending on where exactly you would like to place your solar panel to receive sunlight will be up to you. The example I am going to use for this eBook is a standard shed's roof to mount the solar panel on top of.

*Note: Be sure to check your local weather forecast to make sure no rain is expected for at least two days. The roofing cement that you will be using will need time to adhere to the hole you will be drilling into the roof later on. Also, **check with your landlord to see if you have permission to attach a DIY solar panel to your roof before proceeding.**

1. The items you will need for this step are as follows:

- 3x 5/4" x 6" x 3 1/2 ft. Pieces of Pressure Treated Plywood
- 2x 4" x 4" x 4 ft. Pieces of Pressure Treated Plywood
- 14x L-brackets
- Ladder
- Tape Measure
- Power Drill
- Drill Bit
- Hammer
- 3" screws (made for pressure treated plywood)
- 4" screws (made for pressure treated plywood)
- 2 1/2" screws (made for pressure treated plywood)
- Caulk Gun
- Roofing Cement

2. The first step to preparing your solar panel to be mounted on the roof is

adding plywood strips to the back of the solar panel. This will allow you to easily screw into the strips instead of having to drill directly into the solar panel frame.

To achieve this, simply evenly spread out the three 5/4" x 6" x 3 1/2 ft. pieces of plywood on the backside of the solar panel. Refer to the image below:

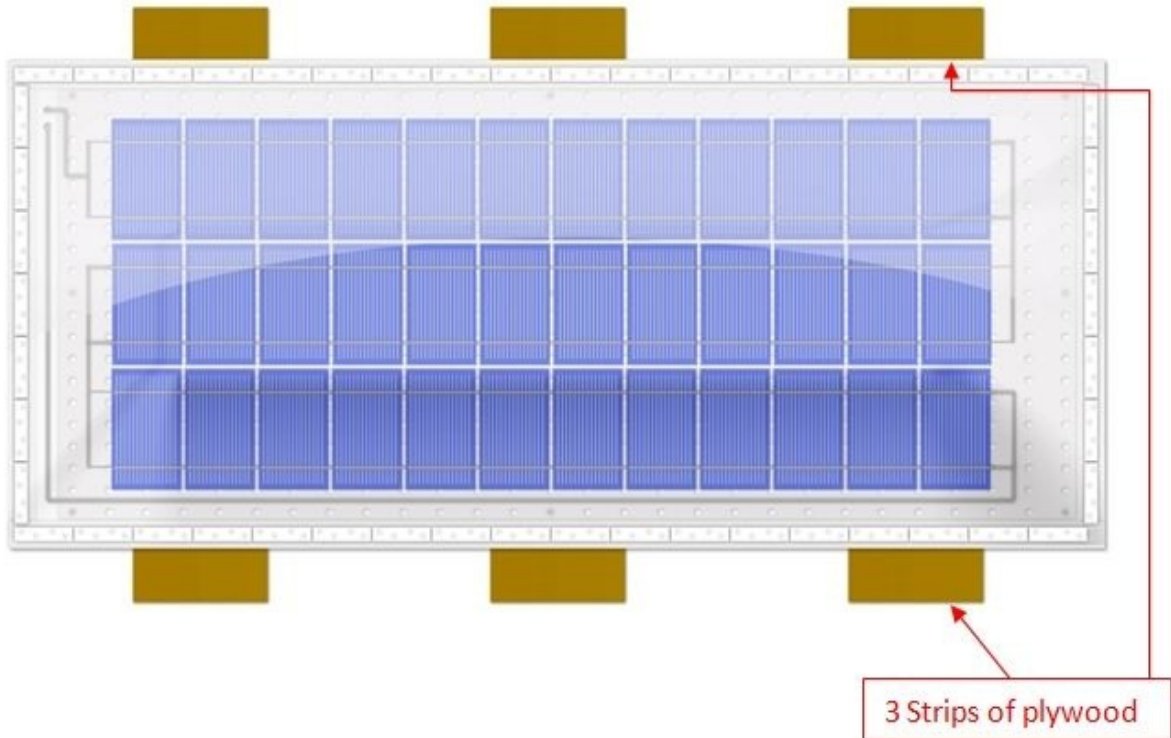

Flip over the solar panel to its backside, and once you have your three 5/4" x 6" x 3 1/2 ft. pieces of plywood in place, take your power drill and pre-drill 3 holes on both the left and right side of the 3 pieces of plywood into the solar panel.

*FYI: Optional: You can paint the white strips white with the same paint used to paint the frame. Since the plywood is pressure treated, either way will be fine, it is totally up to you.

*Tip: Be sure you do now drill into any screws currently inside the side of

the frame. I recommend you take a look at the front side of the frame and find out where all your screws are before pre-drilling.

Refer to the image below:



After you have pre-drilled your holes, you can now screw in the 2 ½” screws into the pre-drilled holes. Once you have finished, you should now be able to lift the entire solar panel by just lifting the three pieces of plywood on the backside.

3. Now that you have added support to the back of your solar panel, you need to create some type of rail for the solar panel to sit on top of on the roof. Since the solar panel is made mostly out of wood, it will be easier to use pressure treated plywood for the rails.

For this step, take the two 4” x 4” x 4 ft. pieces of pressure treated plywood, and lay them down in parallel on an open flat surface. Refer to the image below:

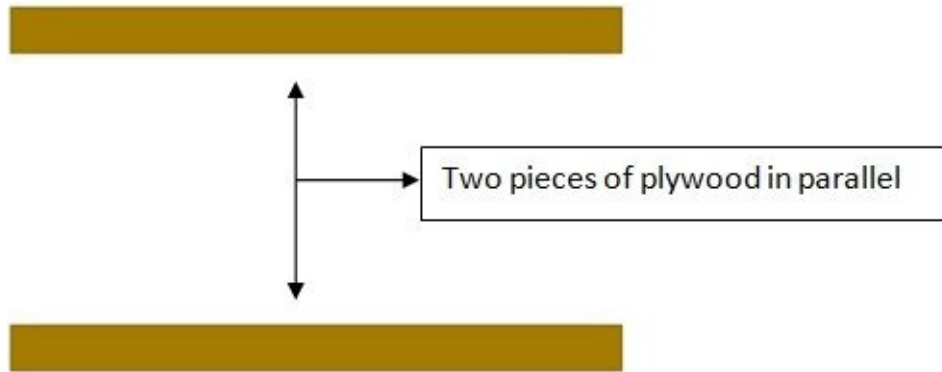

Next, take your solar panel and lay it over top of the two pieces of plywood, and make the necessary adjustments so that the solar panel is centered, and the three pieces of plywood on the backside of the solar panel are on top of the wooden rails.

*Tip: Be sure that you are leaving yourself enough room on the three pieces of plywood on the backside of the solar panel to be able to screw them down to the rails.

Refer to the image below:

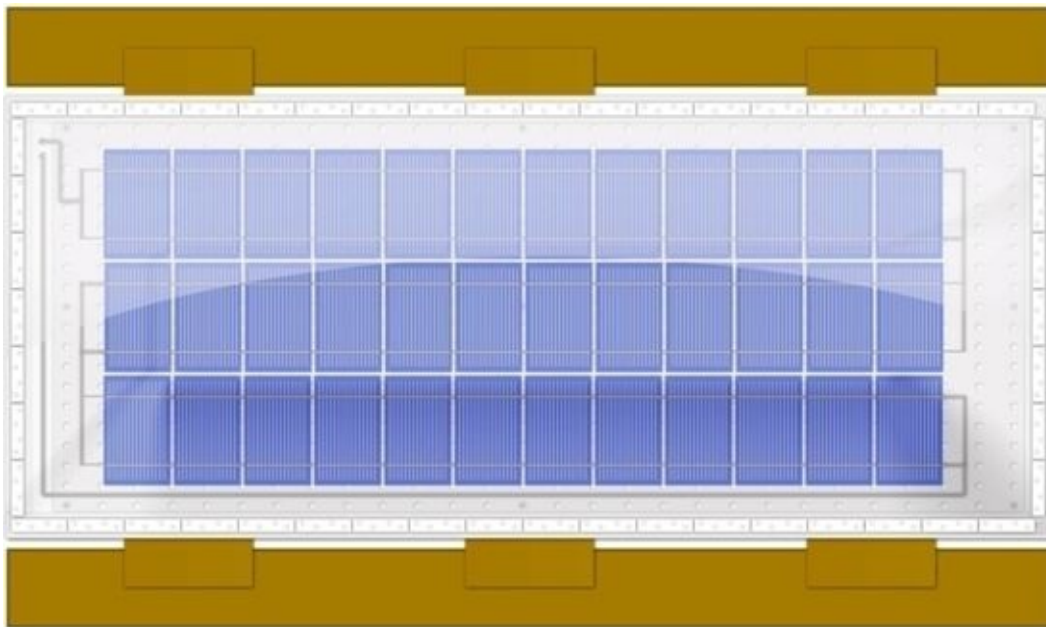

After you have made all the necessary adjustments, while your solar panel is on top of the rails, go ahead and pre-drill three holes on each end of the

three backside pieces of plywood on the solar panel into the rails. **Do not** screw down the solar panel just yet to the rails. However, trace around with a pencil where the three pieces of plywood are positioned on the rails so that you can easily figure out where to position everything later on.

Lastly, with a tape measure, measure the width of both rails and jot that reading down somewhere. Refer to the image below:

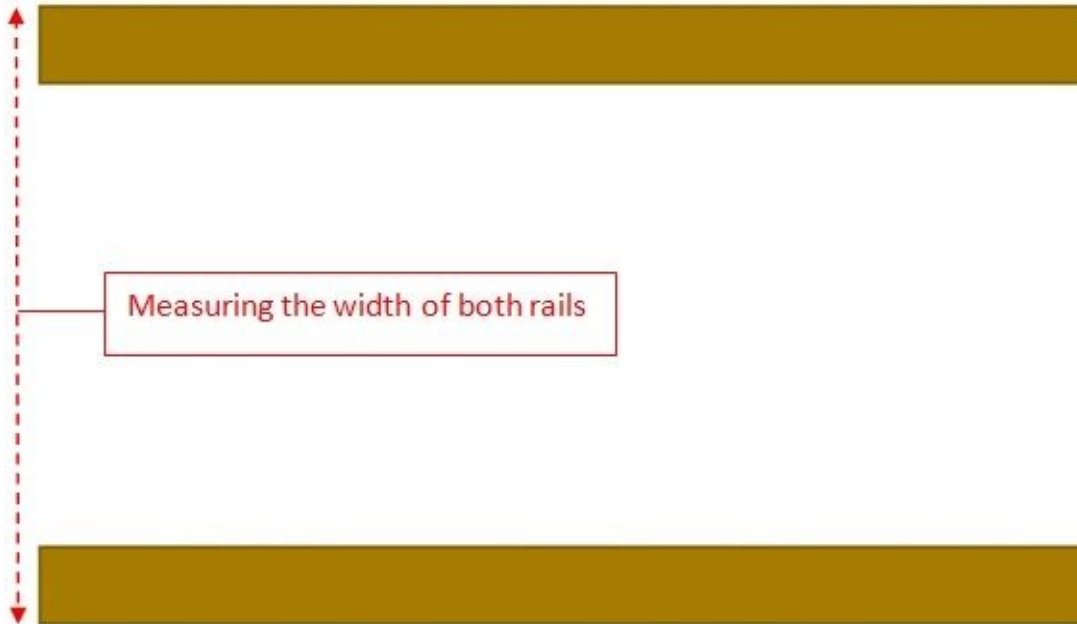

4. Once you have pre-drilled your holes and took all necessary measurements, it will be time to prepare your roof.

The only items you need for this step is, **a ladder, L-brackets, the two rails you created, power drill, drill bits, 4” and 3” screws, tape measure, a hammer, caulk gun, and roofing cement.** It is wise to take all these supplies to the location you’ll be working at so you are not repeatedly climbing on and off the roof.

Next, go ahead place your two rails you created on top of the roof. Before you start to screw down your rails, you need to find the studs in the roof. Using the hammer, lightly tap around on the roof, and you will notice in some places the sound is lighter or thicker. Where the sound is thicker or sounds more solid is where you want to attach your

rails. Depending on how your roof is made, it may not be possible to have both rails screwed into the studs; however, your goal is to try to have at least 1 rail screwed into a stud.

Once you find a stud, align it evenly or in parallel with the stud.

*Tip: Most roofs have shingles on top of them, so I used the shingles to help me align the rails evenly.

Now what you do not want to accidentally do is, place the rails directly over the studs, but instead, place them next to the studs. You will use your L-brackets to secure the rails to the roof.

Next, take one L-bracket and place it near the top right corner of the right side rail. While the L-bracket is in place, use the power drill to pre-drill your holes through the L-bracket into the roof (through the stud), and into the side of the rail. Then take two 4" screws and screw those into the roof side of the L-bracket. Next take two 2 ½" screws and screw those into the rail through the L-bracket. Refer to the image below:

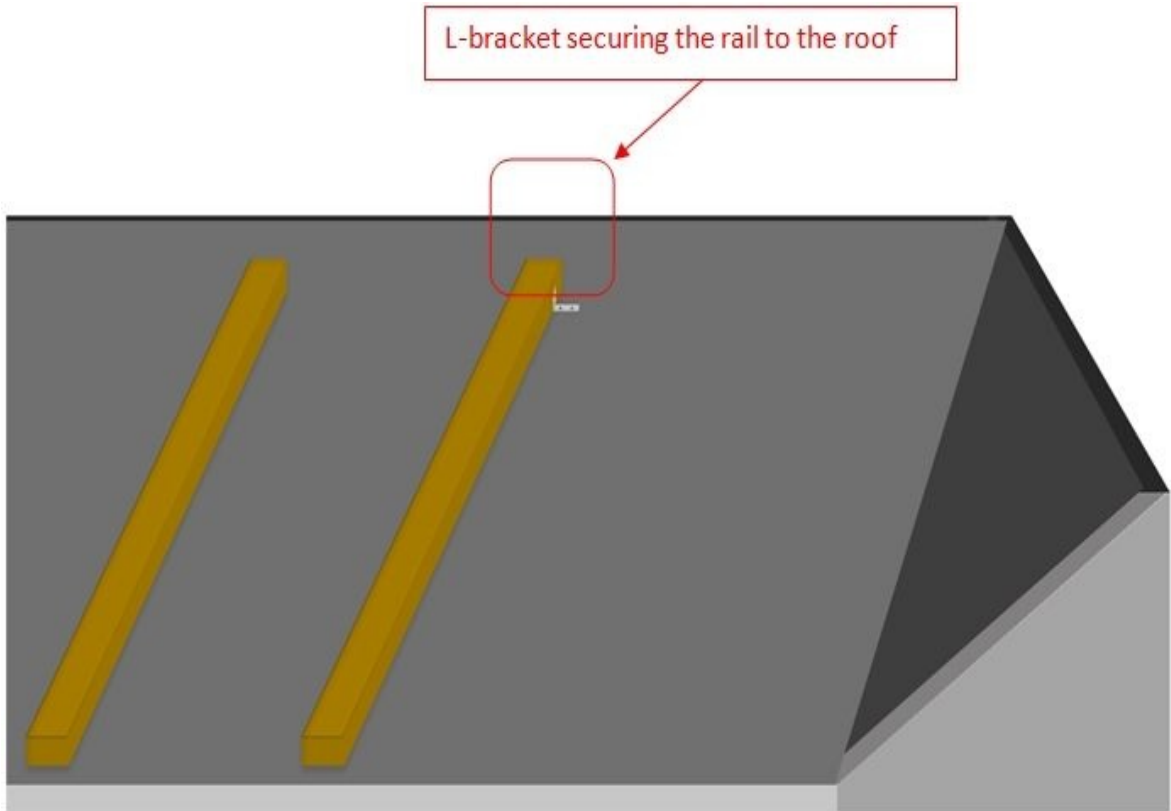

*Tip: It may be easier for most to mark with a pencil or marker where the holes need to be drilled and pre-drill your holes where you feel more comfortable, such as on some horses.

Now, take another L-bracket and place the second L-bracket near the center of the rail and repeat the same process you did for the first L-bracket.

Lastly, take another L-bracket and place the third L-bracket near the bottom right side corner of the rail. Again, repeat the same process for the previous two L-brackets.

Refer to the image below about how the three L-brackets should look after you complete attaching all three L-brackets to the roof and rail.

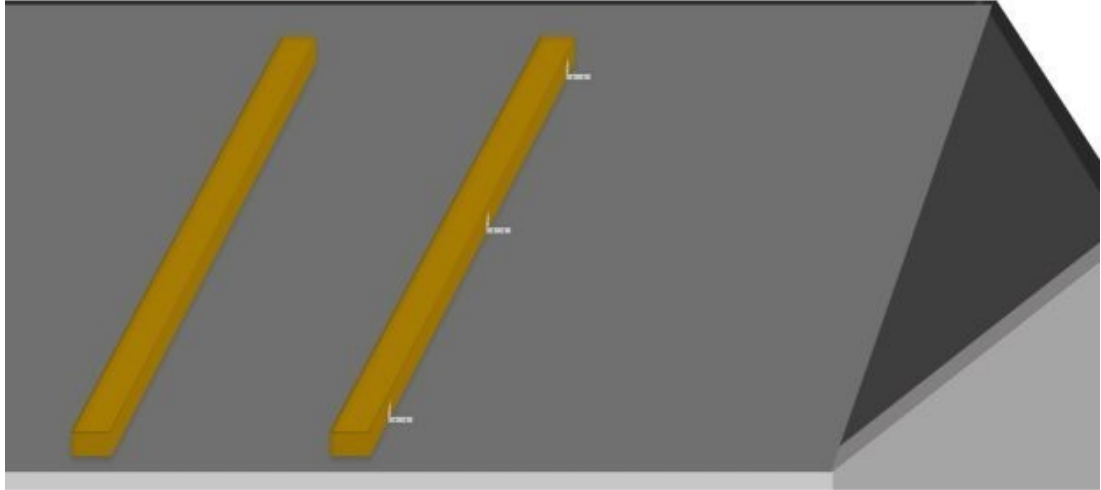

Repeat the entire process over for three more L-brackets, however, place these L-brackets on the left side of the right rail. If you are unable to screw your screws into the studs, do not worry, as you have one side already screwed into one stud. Refer to the image below on how you should position the L-brackets on the left side of the right rail.

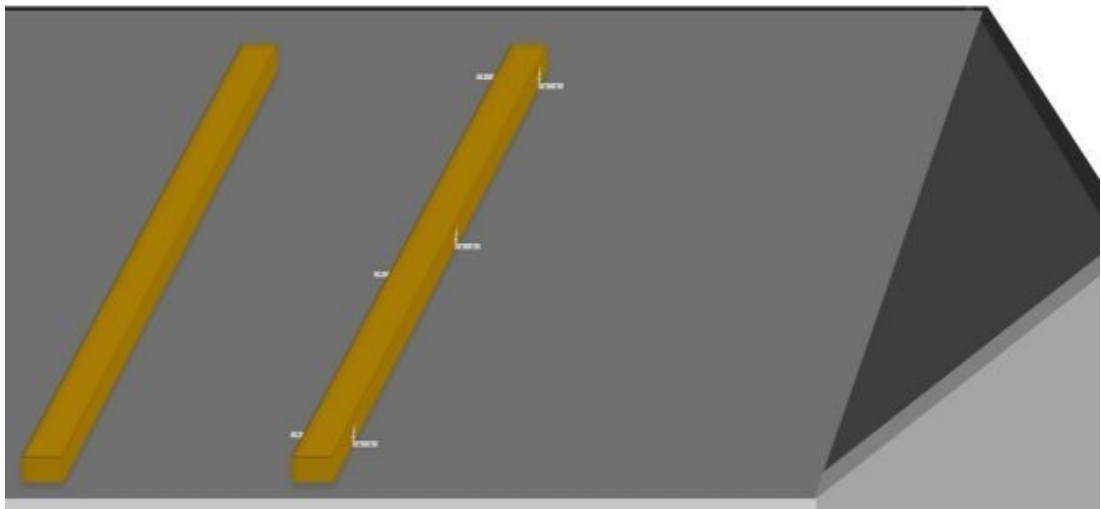

After placing the other three L-brackets on the left side of the right rail, take one more L-bracket and screw it in place in front of the rail. This will prevent the rail from sliding downward. Refer to the image below for a visual:

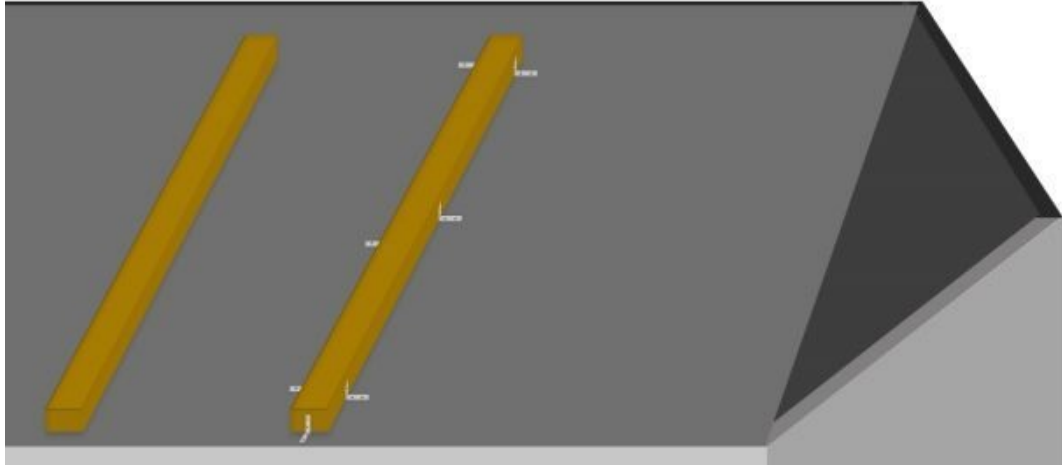

Next you need to apply the same approach to your second rail on the left side, however, it is very important that you use the measurement you took previously when the solar panel was on both rails to align it to the right width with the other right rail in parallel .

If you are unable to screw your screws into a stud for the left side rail, do not worry, as remember, the right side rail has one side of screws screwed into one stud. Refer to the image on the following page for a visual of how both rails should be position after you complete screwing in all your L-brackets in place:

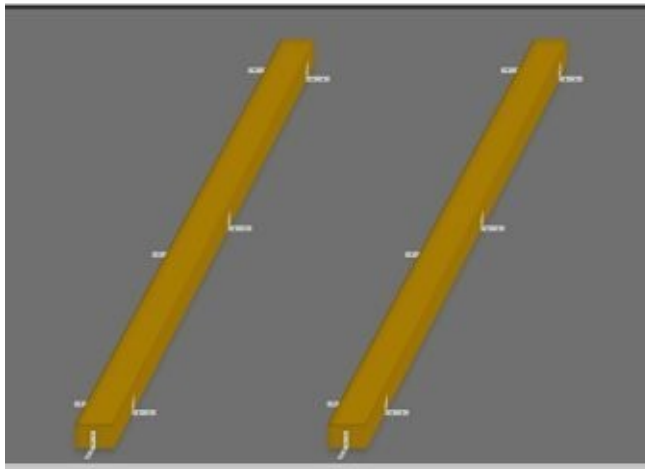

5. Once both rails are in place, you need to drill a hole into the roof so the junction box wires can fall through. Depending on which side you placed your junction box on your solar panel will determine which side to drill the hole between the two rails. The hole only needs to be wide enough for the

two junction box wires to fall through. Refer to the image below:

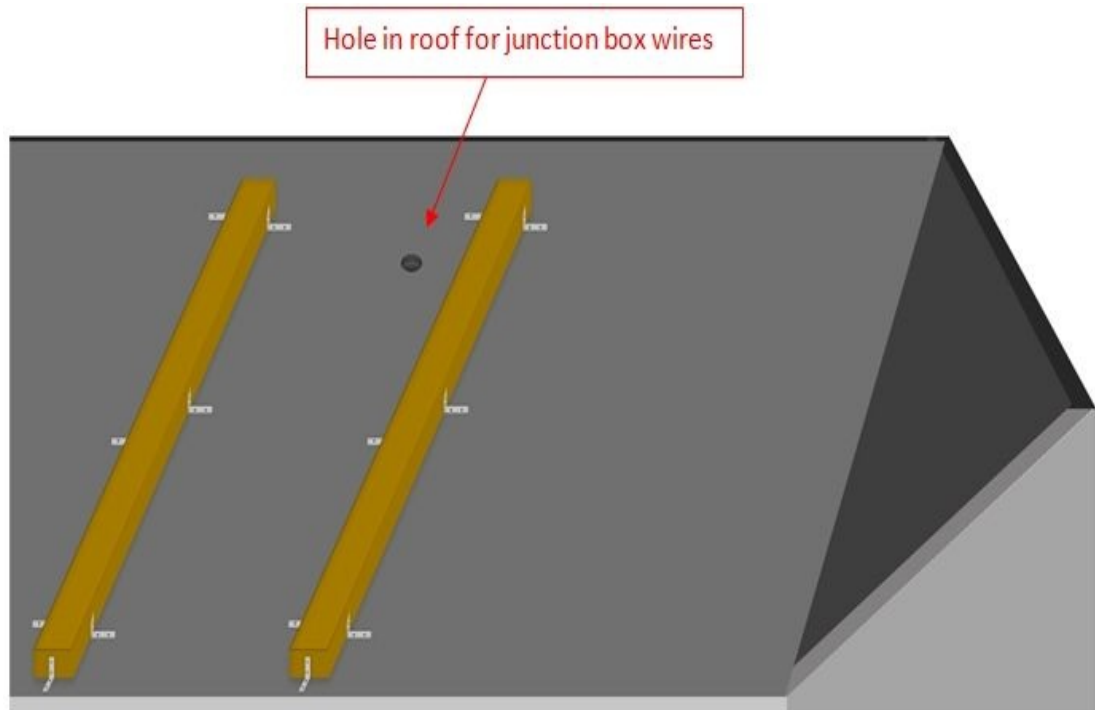

6. Next we can place the solar panel on top of the two rails on the roof.

*Tip: The solar panel can be fairly heavy, so if needed, have someone help you lift it on top of the rails. Depending on how steep your roof is, the solar panel should stay put once it is on the rails without any extra support.

*Tip: **IMPORTANT:** Before you cover up the hole you drilled into the roof, go ahead and slide the wires coming from the junction box inside the hole.

Once you have placed the solar panel on both rails, make any necessary adjustments so that the solar panel is centered between the rails. Refer to the image below:

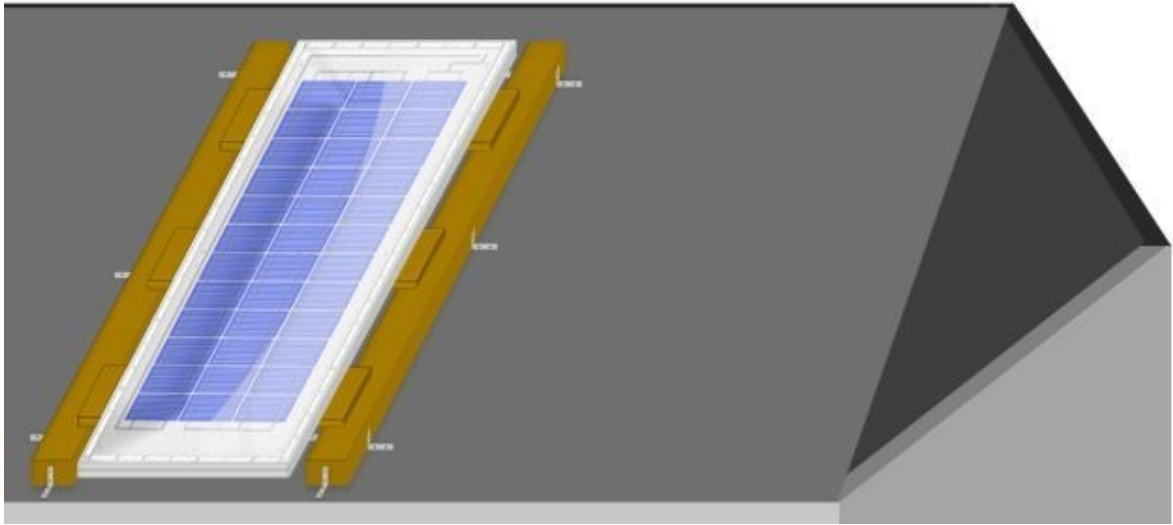

Next you will need to screw the solar panel down to the rails. For my solar panel I built, I screwed three 2 ½” screws into each pieces of plywood on the backside of the solar panel into the rails. I recommend that you pre-drill your holes to make the process easier. Refer to the two images below for a visual:

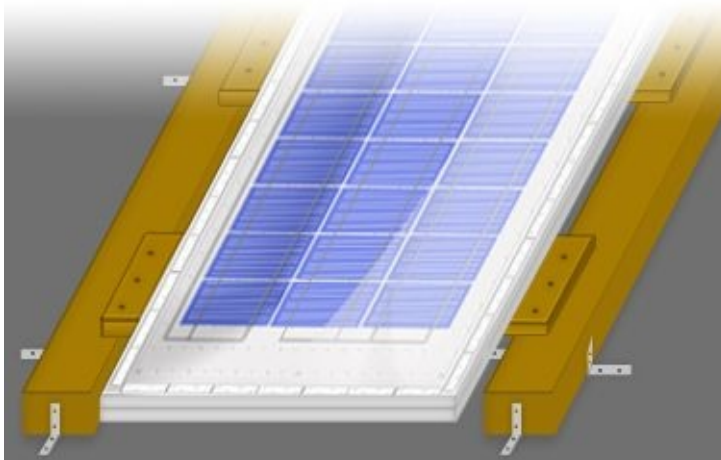

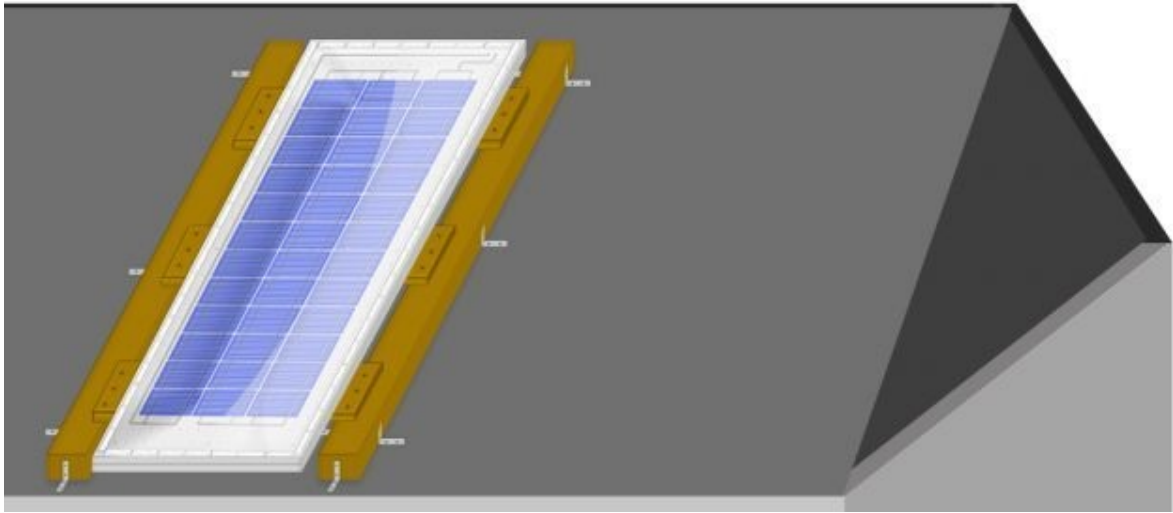

7. Once you have screwed the solar panel in place completely, you have finished installing the solar panel on the roof. Now you need to go inside the shed and apply some roofing cement to the hole you drilled into the roof.

Apply the same concept you used with the silicone in the caulk gun for the roofing cement. Make sure the hole is completely sealed with the cement solution, and follow any additional instructions the roofing cement may recommend.

8. Lastly, from here it should be straight forward. You will need to take the junction box wires and hook them up to your charge controller as shown in the diagram in Step 7. You may have to buy extra wiring depending on where your charge controller and other solar components are located. For a reminder I have provided the wiring diagram below:

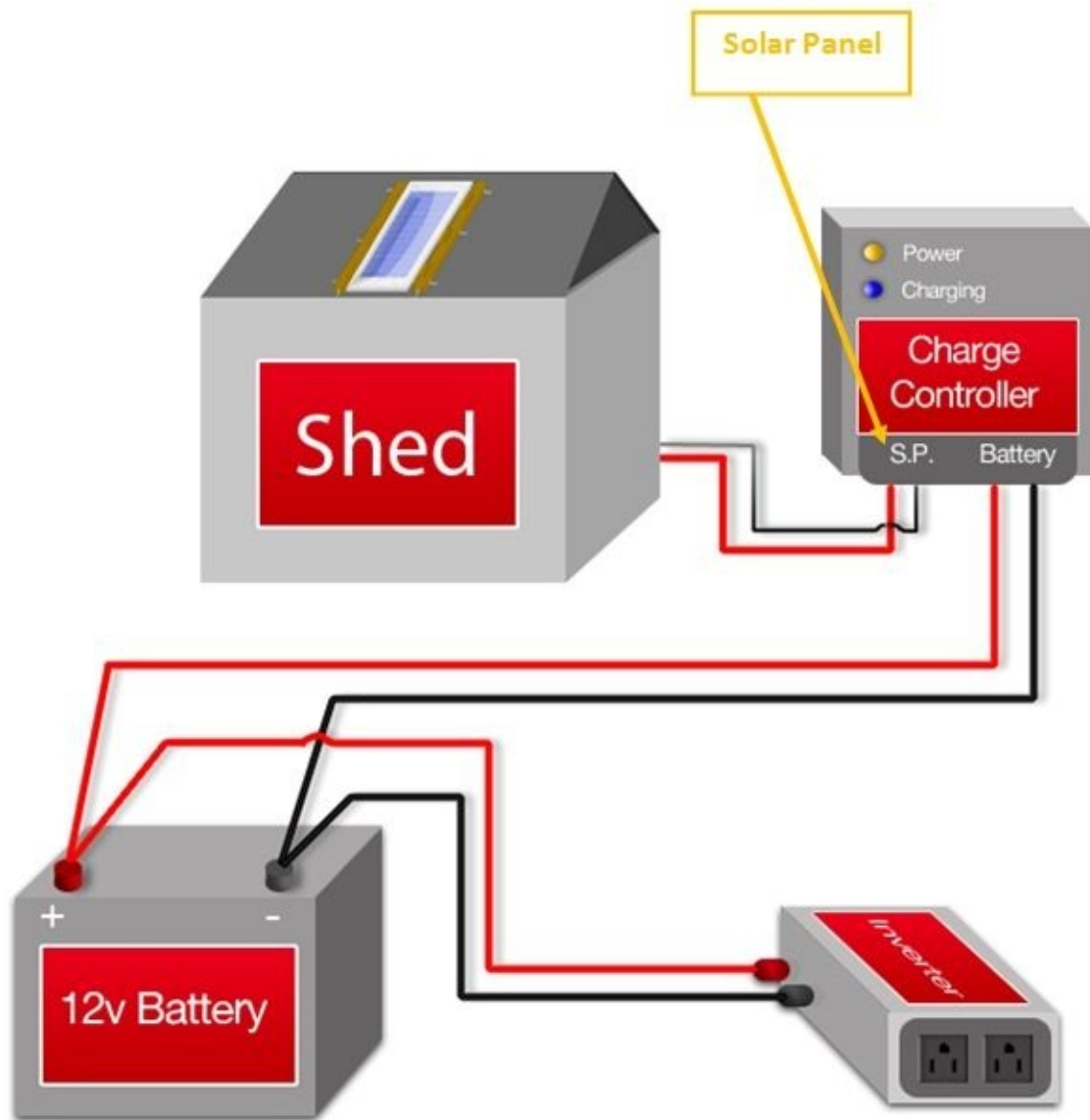

Conclusion

After reading this eBook, you should now have a basic understanding of one method you can use to build a solar panel and a solar power system. The journey does not have to stop here though. There are still many ways you can expand the use of your solar power system. Some people add more solar panels to their solar power system. Some upgrade their inverter to a pure sine wave inverter. Some upgrade their charge controller. Some even find out that they rather purchase professionally made solar panels instead of building them. The route that you can take after this point is endless. There is nothing more exciting to know that you are producing your own clean renewable energy, and can use that energy both during the day and night.

I hope that this was a fun experience for you and that you now have a better understanding of how to build a solar panel and a solar power system.